

DATE	BY	REV.	BY
		FOR REVISIONS	
		SEE SHEET #5	

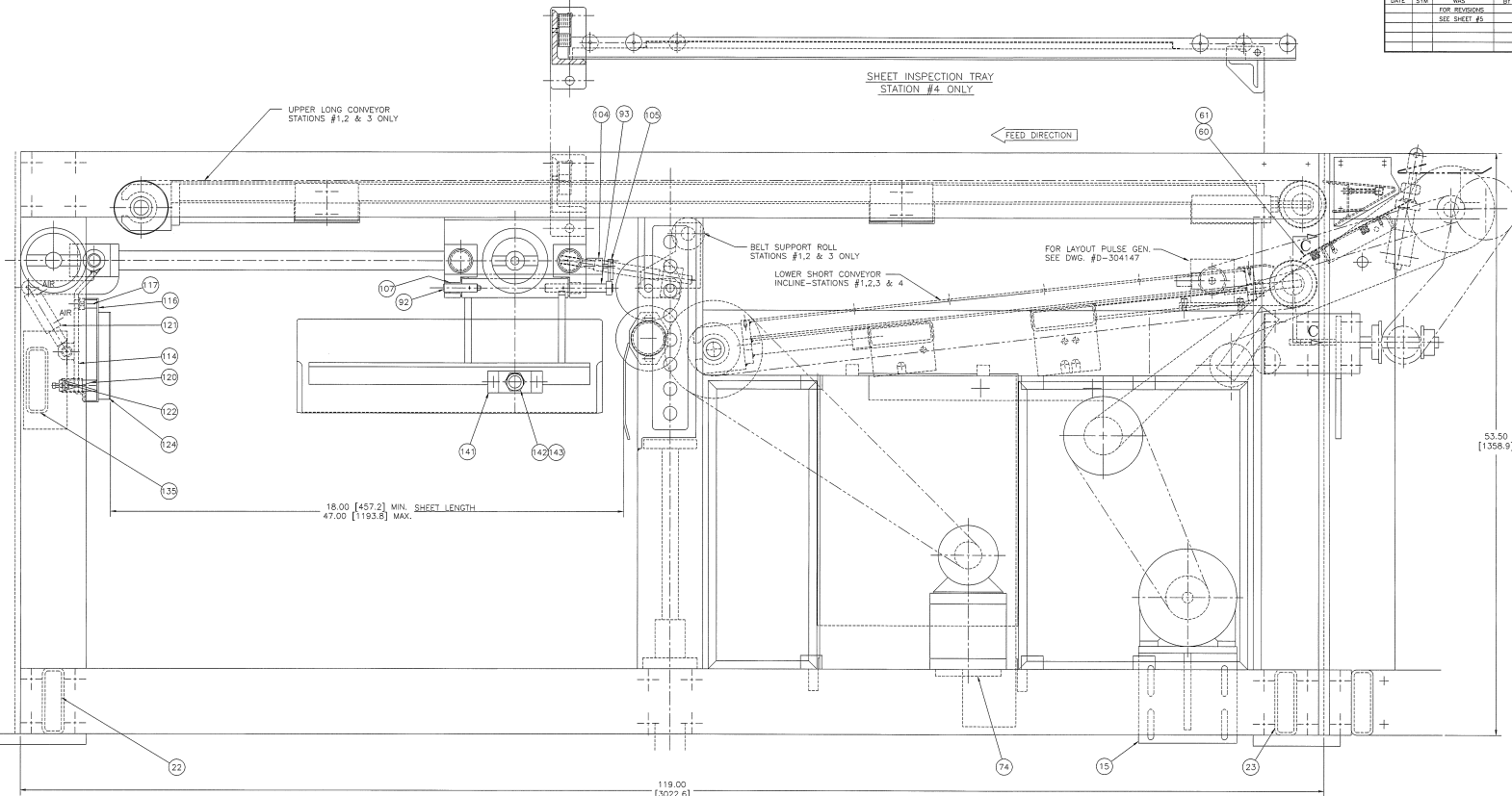

SHEET INSPECTION TRAY  
STATION #4 ONLY

← FEED DIRECTION

BELT SUPPORT ROLL STATIONS #1, 2 & 3 ONLY

LOWER SHORT CONVEYOR INCLINE-STATIONS #1, 2, 3 & 4

FOR LAYOUT PULSE GEN. SEE DWG. #D-304147

18.00 [457.2] MIN. SHEET LENGTH  
47.00 [1193.6] MAX.

118.00 [3022.6]

53.50 [1358.9]

DETAIL "A"

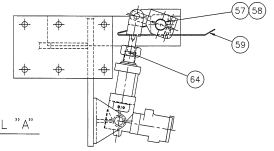

METRIC STD. L.S. CONV. - D-306060

UNLESS OTHERWISE SPECIFIED DIMENSIONS ARE IN INCHES		COPYRIGHT © 2004 VERNER INTERNATIONAL GROUP INC. ALL RIGHTS RESERVED. THE DESIGNATION OF TRADEMARKS, REGISTERED OR UNREGISTERED, AND PATENTS OR PATENT RIGHTS OF OTHERS ARE HEREBY ACKNOWLEDGED AND RESERVED BY VERNER INTERNATIONAL GROUP INC.	
138	MINOR NON-FRAME DIMENSIONS	CHGD	05/23/02
±	TOLERANCE ±	CHG	05/21/02
±	0.005	CHG	05/21/02
±	0.002	CHG	05/21/02
±	0.001	DATE	05/21/02
±	0.0005	FILE	05/21/02
±	0.0002	SCALE	1" = 4" STUCKER
±	0.0001	VIEW	FRONT VIEW
±	0.00005	DRWG NO.	310910
±	0.00002	SCALE	25:1 (0.04)

