

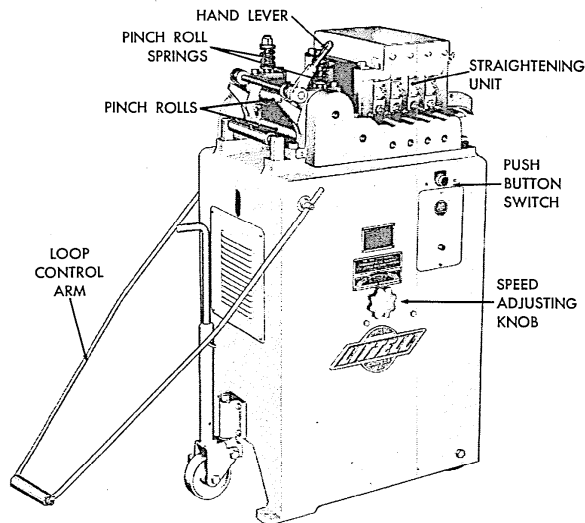

PARTS LIST AND OPERATING INSTRUCTIONS FOR NUMBER 308-9PDS AND NUMBER 312-9PDS VARIABLE SPEED STRAIGHTENING MACHINE WITH MECHANICAL SPEED VARIATOR



OPERATING INSTRUCTIONS

ELECTRICAL CONNECTIONS

Check motor furnished with machine for operating voltage. Connect to power source of proper voltage and electrically ground machine before putting into operation. See wiring diagram furnished with machine.

ELECTRICAL CONTROLS

The machine is equipped with a magnetic starter and a selector type push button station arranged for manual or automatic operation.

For manual operation or "jogging", turn selector button sleeve counterclockwise to "Jog" position and press button. Machine will operate only as long as button is depressed.

For automatic operation, turn selector button sleeve clockwise to "Run" position. The machine will run continuously unless the loop control arm is in the extreme "Down" position.

LUBRICATION

Before placing machine into operation, check all parts for proper lubrication. Lubrication requirements are as follows:

- Electric Motor.** Lubricate in accordance with motor manufacturer's recommendations.
- Speed Reducer.** Keep filled to "Oil Level Plug" using oil as specified on data plate attached to Reducer.
- Straightener Unit.** Lubricate all operating parts daily with a high grade pressure gun grease or #40 S. A. E. oil.
- Straightener Unit Gear Train.** Lubricate gear train at least once a week with S. A. E. 600W fluid grease.

FEEDING DIRECTION

The machine, as shipped, is arranged for right to left direction of operation. If left to right operation is

desired, remove hand lever on upper pinch roll lifter shaft and the operating push button and mount on opposite side of machine. NOTE: The speed adjusting knob and speed indicator plate are not reversible.

STRAIGHTENER UNIT ADJUSTMENT

The upper straightener rolls must be individually adjusted for the thickness, width, and temper of the material to be straightened. Higher settings are required for thicker and softer materials; lower for thinner and harder materials. Individual adjustment of the upper rolls is accomplished by raising the straightener unit cover, unmeshing the slip gears, and setting each roll with the handle provided. The first or incoming upper roll should be set lower than the remaining rolls so as to give a slight up curve to the material. Each remaining upper roll is then adjusted to a higher setting than the preceding roll to bend the material back to the desired straightness. It may be necessary to experiment with different settings to find the best for your material. Once found, record the settings indicated on the dials for the specific material being straightened.

After adjustments are made, remesh slip gears so the straightener head can be raised or lowered as a unit without disturbing the relative adjustment between rolls.

PINCH ROLL ADJUSTMENT

The pinch roll springs must be drawn down to exert sufficient pressure to pull the material without slippage. Adjust springs evenly to assure straight tracking of the material through the rolls and to avoid creeping to either side. Springs must not be drawn down solid at any time.

SPEED ADJUSTMENT

To prevent running out of material or excessive starting and stopping of straightener, set speed of straightener at speed of using equipment. Calculate approximate feeding speed of the using equipment (strokes per minute x feed length). With straightener running, and arm control just above off position, adjust knob to speed at which stock is being used.

LOOP CONTROL ARM

The loop control arm regulates the loop of material between the straightening machine and using-device by varying the speed of the machine. In addition, it shuts off the motor if the loop in the material exceeds the normal operating depth. These functions are accomplished by the use of two adjustable cams located within the base of the machine. Cam No. 1 actuates the speed variator and Cam No. 2 actuates a limit switch for stopping the motor.

Both cams are adjusted before shipment for proper operation. However, feed length and type of material may require that the adjustment be changed to vary depth and operating position of the arm. To adjust, rotate cams on shaft until desired results are obtained. Set speed variator (Cam No. 1) so that variator lever operates between its high and low points when control arm elevation is just above shut-off point of limit switch (Cam No. 2).

F. J. LITTELL MACHINE CO.

4101 N. RAVENSWOOD AVENUE

CHICAGO, ILLINOIS 60613

Form No. 722-1-65

Page 1



No. 308 AND No. 312 STRAIGHTENING MACHINE

IMPORTANT
 When ordering repair parts, specify part number plus serial number, code number and size of machine. Send all repair parts orders to the Chicago factory.

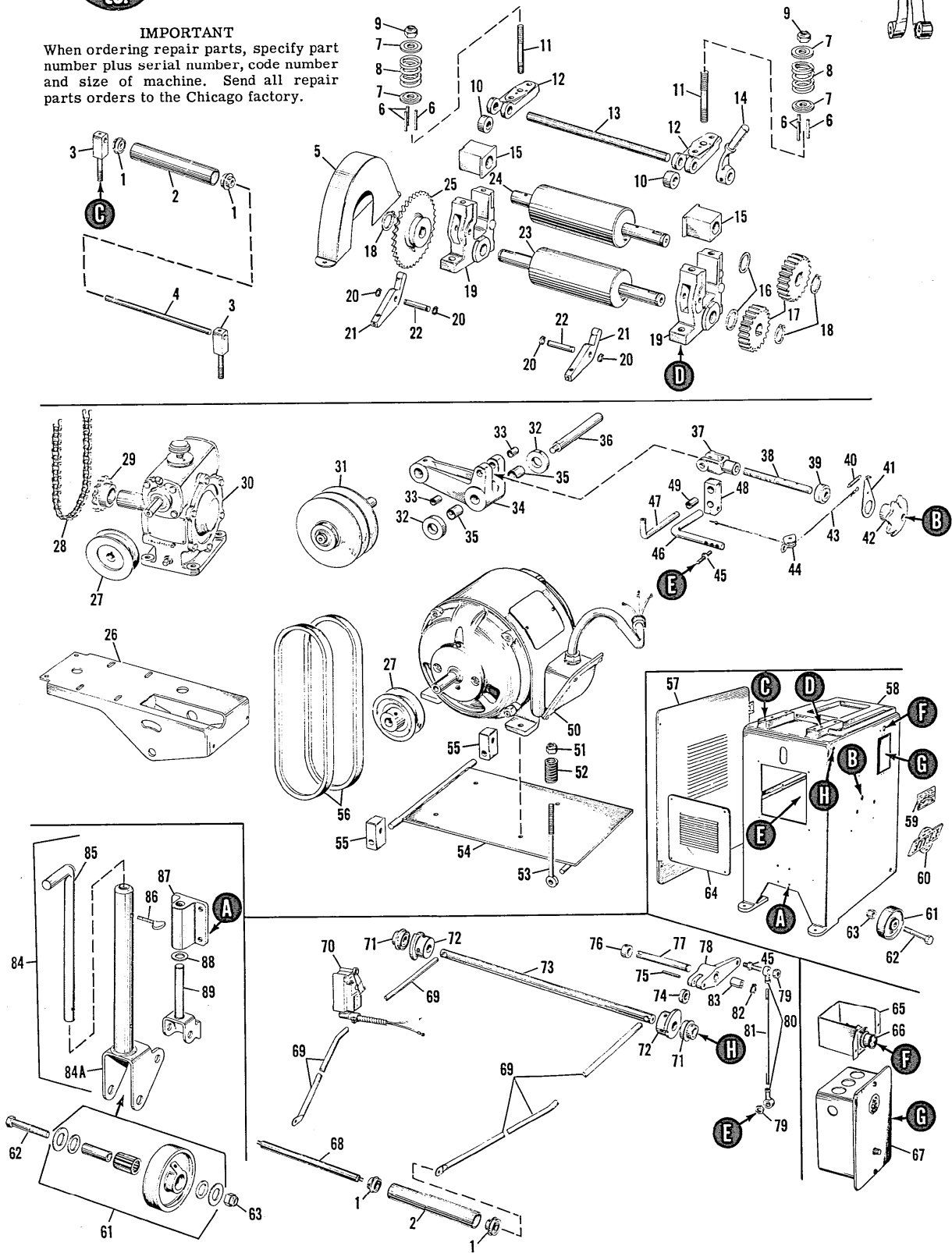
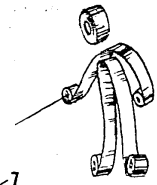

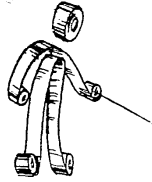

No. 308 AND No. 312 STRAIGHTENING MACHINE



PARTS LIST

INDEX NO.	DESCRIPTION	PART NUMBER	
		#308	#312
1	Bearing, Ball (Schatz #CS-1420)	23 90167	23 90167
2	Roller	23 33580	23 33584
3	Bracket, Roller	23A 33630	23A 33630
4	Shaft, Roller	11 31457	11 31459
5	Guard, Drive Chain	23B 33510	23B 33510
6	Pin, Dowel, 1/4" x 1-3/4"	13 91492	13 91492
7	Washer, Spring	14A 32147	14A 32147
8	Spring, Main Bearing	13A 31772	13A 31772
9	Nut, Lock, Elastic	5/8" - 11	5/8" - 11
10	Cam, Eccentric	13A 31786	13A 31786
11	Stud, Spring	13A 31846	13A 31846
12	Cap, Main Bearing	23A 33655	23A 33655
13	Shaft, Lifter	14 32121	14 32125
14	Handle, Lifter	13 32018	13 32018
15	Assembly, Upper Roll Box	13A 32089	13A 32089
16	Spacer, Roll Gear	23A 33513	23A 33513
17	Gear, Roll	13A 31849	13A 31849
18	Ring, Retaining (Waldes Truarc #5100-112)	23 90060	23 90060
19	Sub-Assembly, Main Bearing	13B 40611	13B 40611
20	Ring, Retaining (Waldes Truarc #5100-50)	13 90922	13 90922
21	Lever, Lifter	23A 33544	23A 33544
22	Pin, Fulcrum	13A 31983	13A 31983
23	Sub-Assembly, Lower Roll	23B 40128	23 40130
24	Sub-Assembly, Upper Roll	13 40046	13 40048
25	Sprocket, Driven	23 91400	23 91400
26	Bracket, Speed Reducer	23D 33541	23 33542
27	Pulley, .750" Bore	23A 33650	23A 33650
28	Pulley, .875" Bore	23A 15413	23A 15413
28	Chain, Roller (Mfg. Std. #50)	23 90917	23 90917
29	Sprocket, Drive	23 91399	23 91399
30	Reducer, Worm Gear, 25:1 Ratio (Cleveland)	23 91176	23 91176
30	Reducer, Worm Gear, 50:1 Ratio (Cleveland)	23 91177	23 91177
31	Pulley, Vari-Speed (McLear Model #6)	23 90934	23 90934
32	Collar, Pivot Shaft	23A 33610	23A 33610
33	Bushing (Oilite #A-1110)	23 90348	23 90438
34	Arm, Pivot	23B 33653	23B 33653
35	Bushing (Oilite #A-746-3)	38 90339	38 90339
36	Shaft, Pivot Arm	23A 33548	23A 33548
37	Clevis	23A 33657	23A 33657
38	Screw, Adjusting	23A 33576	23 33577
39	Collar, Adjusting Screw	23A 33606	23A 33606
40	Spring, Pointer (Gardner #E-18C)	41 90043	41 90043
41	Pointer	23A 33611	23A 33611
42	Knob, Hand, Palm Grip	23A 33659	23A 33659
43	Rope, Flexible Wire, 1/16" Dia.	23 90991	23 90991
44	Pulley, Awning (Fast Eye)	23 90935	23 90935
45	Pin, Anchor	23A 33612	23A 33612
46	Pin, Link	23A 33543	23A 33543
47	Pin, Clevis	23A 33632	23A 33632

INDEX NO.	DESCRIPTION	PART NUMBER	
		#308	#312
48	Link, Pivot Arm	23A 33605	23A 33605
49	Bushing (Oilite #AA-628)	13 90335	13 90335
50	Motor	91 90660	91 90662
51	Nut, Lock, Elastic	3/8" - 16	3/8" - 16
52	Spring (Danly Die #9-1610-11)	23 90005	23 90005
53	Rod, Spring	23A 33525	23A 33525
54	Plate, Motor	23A 33526	23A 33526
55	Bracket, Pivot	23A 33508	23A 33508
56	V-Belt (Gates #RVS-248)	23 90966	23 90966
57	Plate, Cover	23A 33527	23A 33527
58	Base	23B 33639	23B 33640
59	Plate, Name	23A 33545	23A 33641
60	Plate, Serial	14A 10151	14A 10151
61	Assembly, Caster Wheel	23A 23651	23A 23651
62	Screw, Cap, Hex Head	5/8" - 11 x 3-1/2"	5/8" - 11 x 3-1/2"
63	Nut, Lock, Elastic	5/8" - 11	5/8" - 11
64	Plate, Louvre	24A 33771	24A 33771
65	Cover, Push Button	23B 33631	23B 33631
66	Button, Push (Allen-Bradley Bull. #800T, Type K2A)	94 90582	94 90582
67	Starter, Magnetic, 220 Volts (Allen-Bradley Bull. #709, Cat. #709AAA)	92 91609	92 91609
67	Starter, Magnetic, 440 Volts (Allen-Bradley Bull. #709, Cat. #709AAB)	92 91610	92 91610
68	Shaft, Roller	23 33551	23 33555
69	Arm, Control	23B 33547	23B 33547
70	Switch, Limit (Square "D" 9007-AW12-C1)	93 90567	93 90567
71	Bearing, Ball (Schatz #CS-1432)	23 90169	23 90169
72	Cam	23A 33658	23A 33658
73	Shaft, Cam	23 33617	23 33619
74	Bearing, Ball (Nice #3014DC)	99 91500	99 91500
75	Pin, Roll, 3/8" x 1-1/2" Long (Esna)	23 90910	23 90910
76	Collar, 5/8" I.D. (Hallowell)	23 90439	23 90439
77	Shaft, Lever Pivot	23A 33615	23A 33615
78	Lever, Roller	23A 33654	23A 33654
79	Nut, Hex, Full	5/16" - 24	5/16" - 24
80	Rod End, Ball (Heim #HF-5)	23 90420	23 90420
81	Rod, Connecting	23A 33614	23A 33614
82	Ring, Retaining (Waldes Truarc #5100-62)	14 90923	14 90923
83	Bushing (Oilite #A-873-4)	23 90343	23 90343
84	Assembly, #308 Steering Truck	23A 17175	23A 17175
84A	Consisting of:		
	Post, Steering Wheel	23B 33546	23B 33546
85	Handle, Steering Wheel	23A 33608	23A 33608
86	Screw, Thumb	5/16" - 18	5/16" - 18
		x 1-1/2" Lg.	x 1-1/2" Lg.
87	Bracket, Steering Wheel	23A 33656	23A 33656
88	Washer, Finished	26 34594	26 34594
89	Pivot, Steering Wheel	23B 33607	23B 33607



No. 308-9PDS AND No. 312-9PDS STRAIGHTENING UNIT

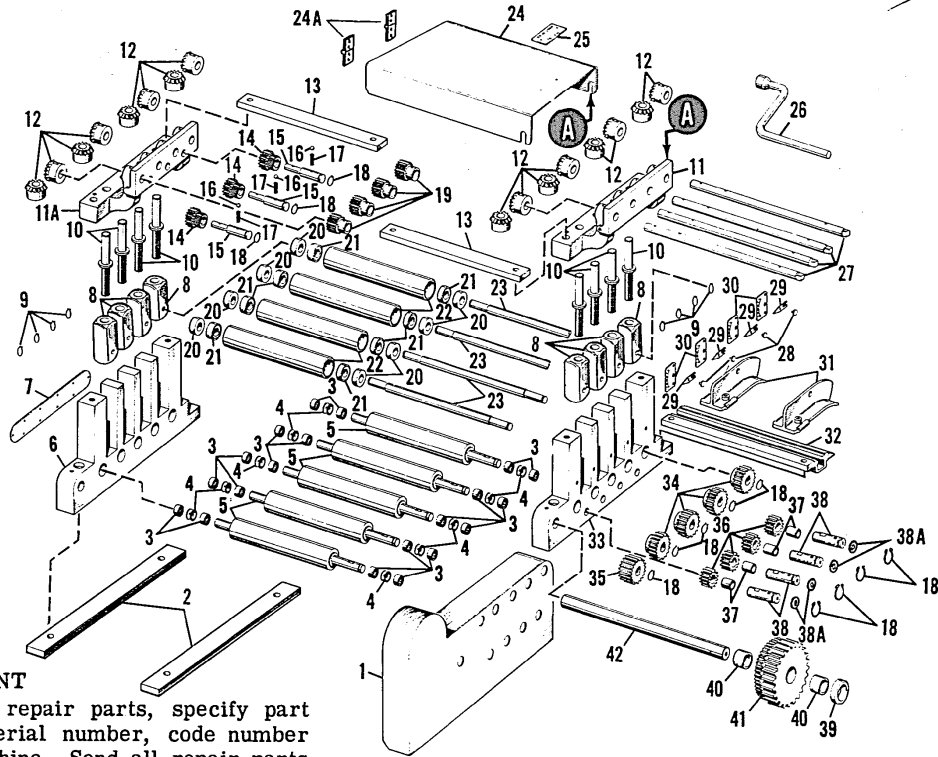
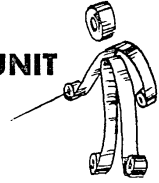

IMPORTANT
When ordering repair parts, specify part number plus serial number, code number and size of machine. Send all repair parts orders to the Chicago factory.

PARTS LIST

INDEX NO.	DESCRIPTION	PART NUMBER		INDEX NO.	DESCRIPTION	PART NUMBER	
		#308-9PDS	#312-9PDS			#308-9PDS	#312-9PDS
1	Guard, Roll Gear	23C 14398	23C 14398	22	Roll, Straightener . .	23 34724	23 34726
2	Spacer, Side Frame	23 47475	23 47475	23	Shaft, Straightener		
3	Bearing, Needle (Torrington #B108)	23 90226	23 90226	24	Roll	23 30753	23 30755
4	Spacer, Bearing Roll and Shaft, Lower	23A 34773	23A 34773	24A	Guard, Top . . .	23B 34789	23 34790
5	Roll and Shaft, Lower	23 30790	23 30792	24A	Hinge (McMaster-Carr #16B28) . .	23 90903	23 90903
6	Frame, Side, Rear	23B 14321	23B 14321	25	Plate, Instruction	24 34902	24A 34902
7	Plate, Cover . .	23A 14397	23A 14397	26	Wrench, Crank . .	13 31890	13 31890
8	Box, Bearing . .	23A 34760	23A 34760	27	Shaft, Adjusting .	23 34741	23 34743
9	Ring, Retaining (Waldes #5100-50)	13 90922	13 90922	28	Pin, Pivot	23 34759	23 34759
10	Screw, Adjusting.	23A 34719	23A 34719	29	Pointer, Indicator	23 34758	23 34758
11	Bracket, Cap and Bearing, Front . .	23B 34839	23B 34839	30	Plate, Indicator Dial .	23A 34757	23A 34757
11A	Bracket, Cap and Bearing, Rear . .	23 47040	23 47040	31	Assembly, "T" Stock Guide . . .	13 32093	13 32093
12	Gear, Miter . . .	23A 34727	23A 34727	32	Table, Stock . . .	23 34832	23 34834
13	Bar, Tie	23 34768	23 34770	33	Frame, Side, Front	23B 14320	23B 14320
14	Gear, Slip, Knurled	24A 14530	24A 14530	34	Gear, Roll	23A 14491	23A 14491
15	Shaft, Slip Gear .	23A 11562	23A 11562	35	Gear, Wide Roll . .	23A 14489	23A 14489
16	Ball, Detent . . .	1/4" Dia.	1/4" Dia.	36	Gear, Idler	23A 41121	23A 41121
17	Spring, Detent . .	13 31778	13 31778	37	Bushing (Bunting #C-93)	23 90293	23 90293
18	Ring, Retaining (Waldes #5100-62)	14 90923	14 90923	38	Pin, Idler Gear . .	24A 18370	24A 18370
19	Gear, Spur	24A 14531	24A 14531	38A	Washer, Steel . . .	23 24179	23 24179
20	Collar, Shaft . . .	23A 34720	23A 34720	39	Collar (Hallowell) . . .	15 90440	15 90440
21	Bearing, Ball (Nice #1623DC) .	23 90250	23 90250	40	Bushing (Bunting #DB-272)	23 90304	23 90304
				41	Gear, Intermediate	23A 41122	23A 41122
				42	Shaft, Intermediate Gear . .	23A 34801	23 34803

F. J. LITTELL MACHINE CO.