

**SUBJECT:**

## Safeguarding & Safety Precautions For LITTELL Straightening Machines.

**WARNING:**

To prevent serious injury to persons involved with LITTELL Straightening Machines, Read & Comply with all of the following safety instructions.

**SAFETY INSTRUCTIONS:**

Immediate action, by users of this machinery, must be taken to apply accident prevention safeguards and safety precautions as specified in this report. Due to today's high probability of employees receiving insufficient training or supervision combined with the possibilities of committing unsafe, careless or negligent acts, this precautionary action is mandatory.

To prevent serious injury to persons in your company, use the safety information contained in this report to assist yourself in accomplishing both the required addition and continued use of the necessary safeguards and safety precautions.

Throughout this report the word "USER" means any individual, partnership, corporation, or other form of enterprise which employs, contracts with, hires, benefits from, or is responsible for the persons who install, setup, adjust, operate, service, maintain, repair or work on or around machinery originally manufactured by Littell.

It is the Employer's responsibility to comply with the OCCUPATIONAL SAFETY & HEALTH ADMINISTRATION'S general industry standards, part 1910, Title 29 of the CODE OF FEDERAL REGULATIONS.

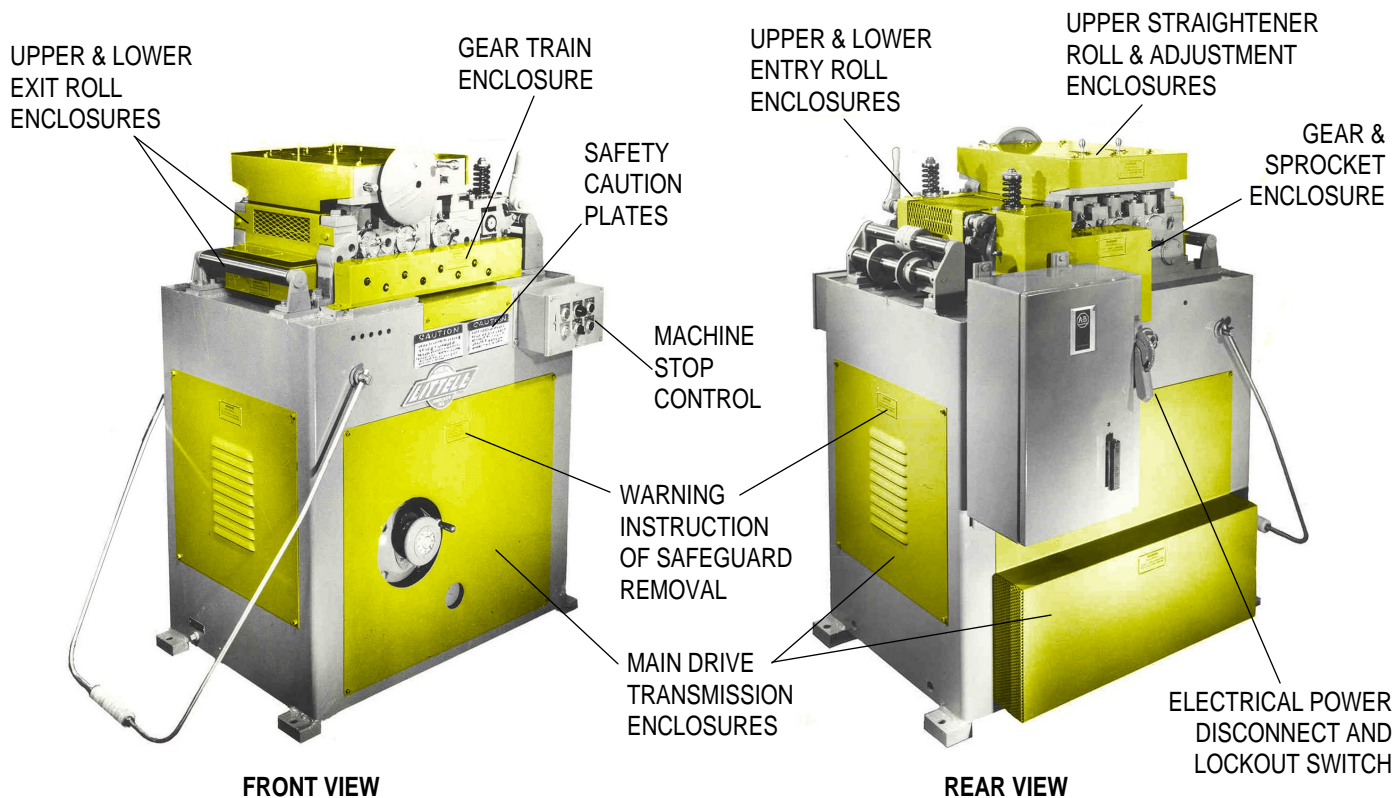

**No. 4 STRAIGHTENER**

Littell has manufactured numerous styles, designs, and sizes of straightening machines for a wide variety of applications for over 50 years. When these machines and their applications are combined with the numerous variety of options, accessories, and manufacturing methods it is easy to understand that standardized, mass produced, and immediately available safeguards from Littell are impractical. Safeguard designs will vary and must be tailored to each individual machine.

However, there are general areas which have common hazards and common solutions for developing the general design of each safeguard.

This report illustrates the design of typical safeguards required for these common areas and provides a guideline that can be used in developing, manufacturing, and applying straightener safeguards.

Compare all the following safeguarding illustrations in this report against your present straighteners and identify those areas which are inadequately protected including existing safeguards which are defective. These areas must be given immediate attention in order to correct deficiencies and to accomplish the addition of the required safeguards.

Special attention must be given to safeguarding all machine rollers which work and propel the material. Present trends indicate that these rollers are high risk and hazardous. They can cause severe injury to fingers, hands, and arms of persons attempting to unsafely clean or thread material while rollers are in motion.

Fixed roll enclosures, allowing passage of material only, must be permanently mounted to the main frame of the machinery and require the use of tools for their removal. These enclosures must prevent access to the roller hazards generally referred to as NIP, PINCH, or SQUEEZE points.

If a special application requires frequent access to the machinery rollers (CONSIDERED RARE) interlocked enclosures must be incorporated. They must create and maintain a "MACHINE SHUTDOWN" and prevent roller rotation whenever the enclosure allows access to the roll hazards.

This report is not intended to illustrate every safeguard which may be required or to limit the application of safeguarding to those shown in this report. It is intended to describe some of the hazards which exist, to require safeguarding to eliminate or to minimize those hazards, and to define certain responsibilities.

To effectively apply a safeguard it must be designed, manufactured, installed and used properly for each application; otherwise persons may seek to circumvent it. The user must become familiar with the various types of safeguards used throughout the industry and determine which type fits his application best and provides maximum protection.

To assist users in judging the safeguarding of machinery a "DIRECTORY OF SAFETY LITERATURE,

STANDARDS & REGULATIONS: has been included in this report. Users should obtain and review this material immediately.

Many manufacturers are equipped to furnish standard or special safeguards. A list of suppliers can be easily found in "BEST'S SAFETY DIRECTORY" of the  
A.M. BEST COMPANY,  
AMBEST ROAD  
OLDWICK, NEW JERSEY 08858

The addition of safeguards is not the sole remedy for accident prevention. To realize maximum protection benefits, the safety precautions in this report must be incorporated into user's safety training programs. Persons involved with Littell machinery must be supervised and tested to determine and continually insure that all have been adequately instructed by demonstrating, with discrete repetition, their awareness and understanding of these safety precautions including other applicable safety practices, codes, standards, and regulations which are not included in this report.

Many accidents have occurred due to a supervisors lack of training; because of this lack of training, the supervisor is incapable of developing the necessary safety awareness and cannot transfer safe work procedures to others.

Users must make certain that only persons who understand Littell machinery, its intended use, care and safety requirements and who are able to communicate this knowledge be given the responsibility of instructing, training, and supervising others involved with this machinery.

It is the users responsibility to interpret and to explain all safety precautions and signs to persons who do not read or understand English BEFORE they are allowed to use and care for this machinery.

**WARNING:**  
ONLY PERSONS WHO THOROUGHLY UNDERSTAND AND COMPLY WITH ALL OF THE GIVEN SAFETY PRECAUTIONS ARE QUALIFIED TO USE AND CARE FOR LITTELL MACHINERY WHICH HAS BEEN SAFEGUARDED AS INSTRUCTED IN THIS REPORT. MAKE CERTAIN THESE PRECAUTIONS ARE APPLIED IMMEDIATELY.

The user must decide what personal protective safety equipment is required to perform each job safely. Items such as safety glasses, shoes, gloves, helmets, spats, protective sleeves and material handling equipment are common in the metal working industry.

## No. 2 Series Straightening Machine Guards:

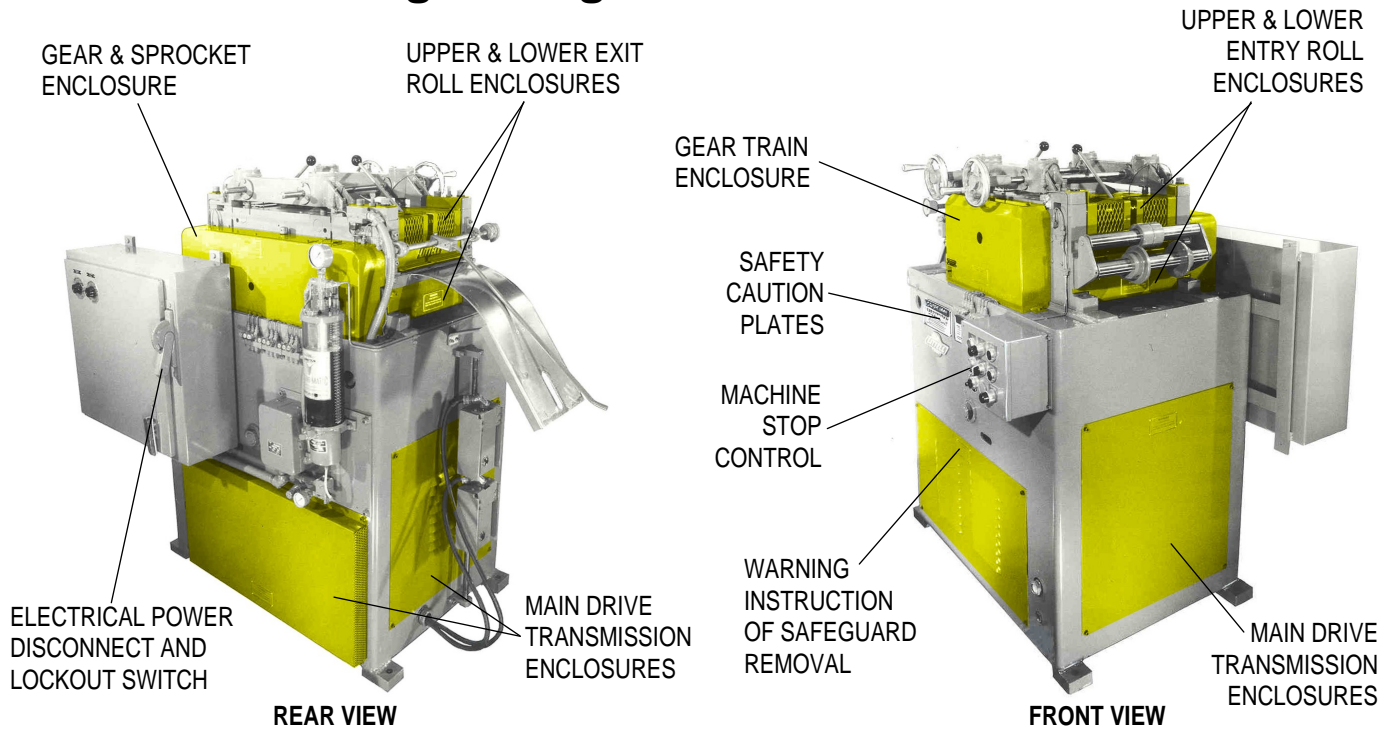

### ENLARGED GUARD VIEWS

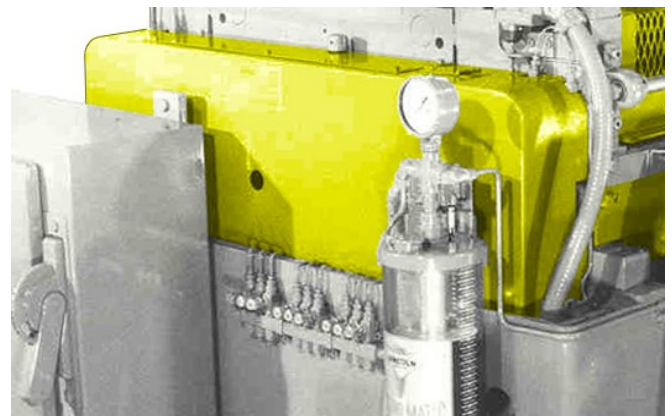
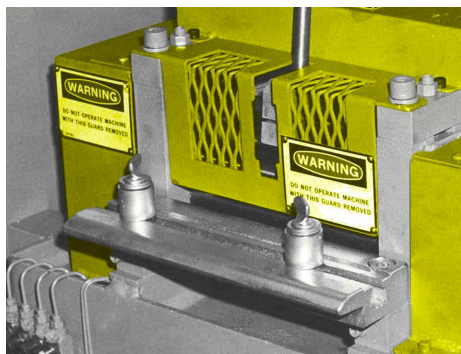
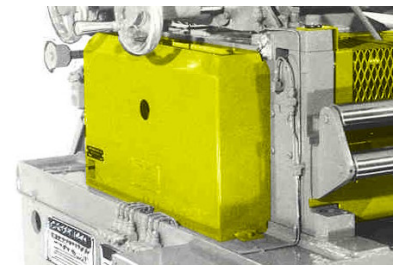
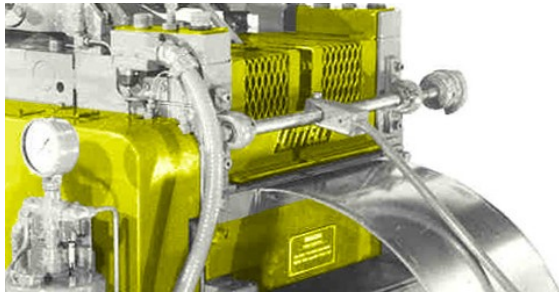

**REVIEW PAGE 10 & 11 FOR GUARDING INFORMATION**

## No. 3 Series Straightening Machine Guards:

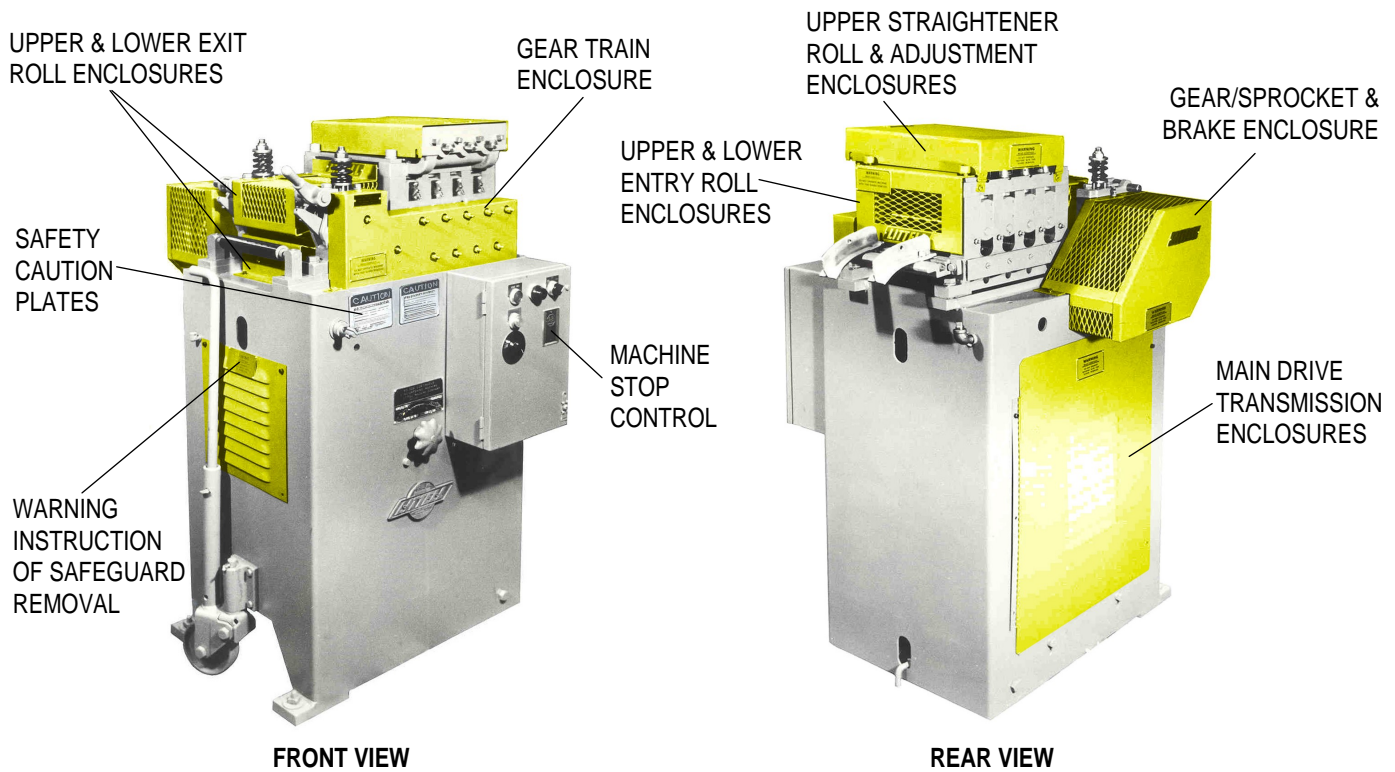

### ENLARGED GUARD VIEWS

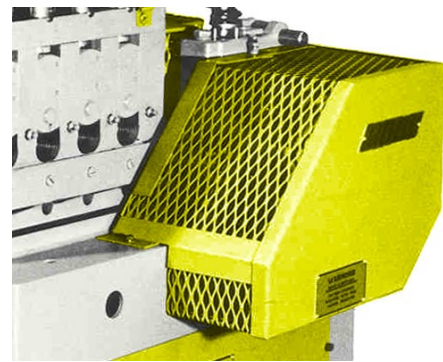
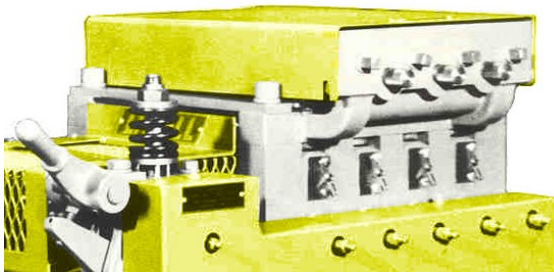
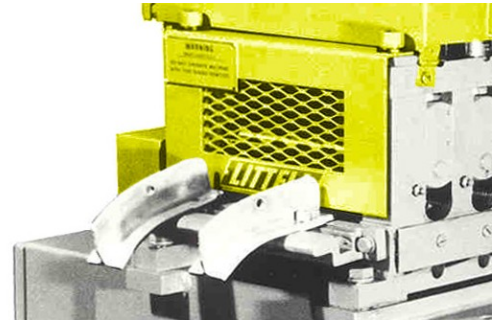
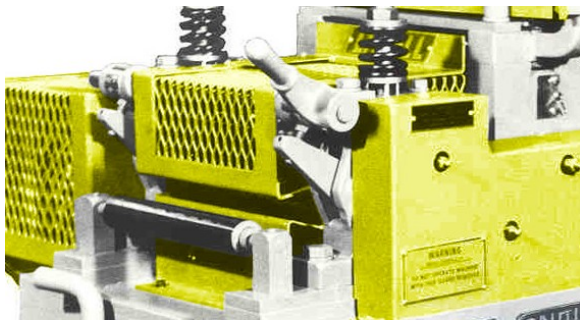

REVIEW PAGE 10 & 11 FOR GUARDING INFORMATION

## No. 3 Series Pinch Roll Machine Guards:

UPPER & LOWER  
EXIT ROLL  
ENCLOSURES

GEAR  
ENCLOSURE

SAFETY CAUTION  
PLATES

MACHINE  
STOP  
CONTROL



**FRONT VIEW**

UPPER & LOWER  
ENTRY ROLL  
ENCLOSURES

GEAR & SPROCKET  
ENCLOSURE

WARNING  
INSTRUCTION  
OF SAFEGUARD  
REMOVAL

MAIN DRIVE  
TRANSMISSION  
ENCLOSURES



**REAR VIEW**

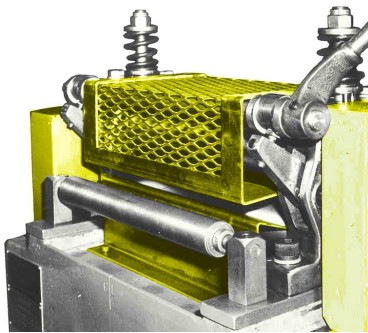

**ENLARGED GUARD VIEWS**

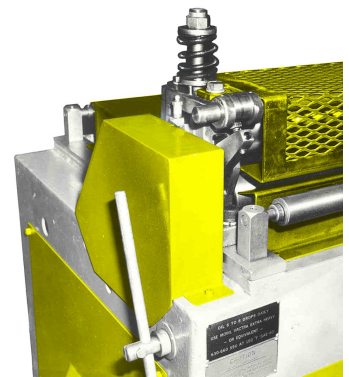
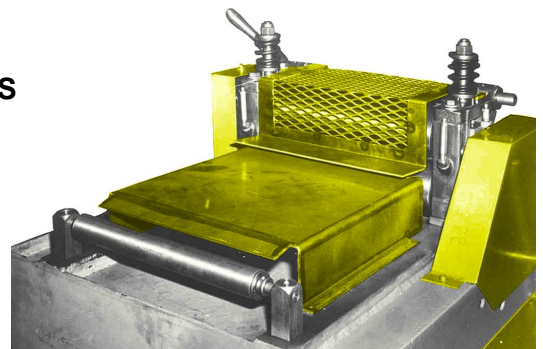
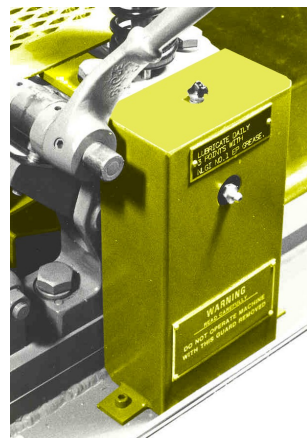

**REVIEW PAGE 10 & 11 FOR  
GUARDING INFORMATION**

## No. 4 Series Straightening Machine Guards:

UPPER & LOWER  
EXIT ROLL  
ENCLOSURES

GEAR TRAIN  
ENCLOSURE

SAFETY  
CAUTION  
PLATES

MACHINE STOP  
CONTROL

WARNING  
INSTRUCTION  
OF SAFEGUARD  
REMOVAL

MAIN DRIVE  
TRANSMISSION  
ENCLOSURES

FRONT VIEW

UPPER STRAIGHTENER  
ROLL & ADJUSTMENT  
ENCLOSURES

GEAR & SPROCKET  
ENCLOSURE

UPPER & LOWER  
ENTRY ROLL  
ENCLOSURES

ELECTRICAL POWER  
DISCONNECT AND  
LOCKOUT SWITCH

REAR VIEW

### ENLARGED GUARD VIEWS

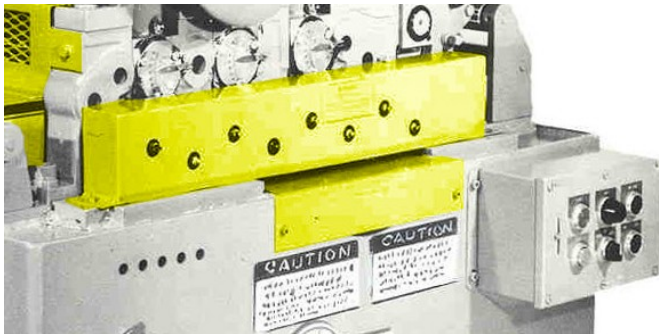
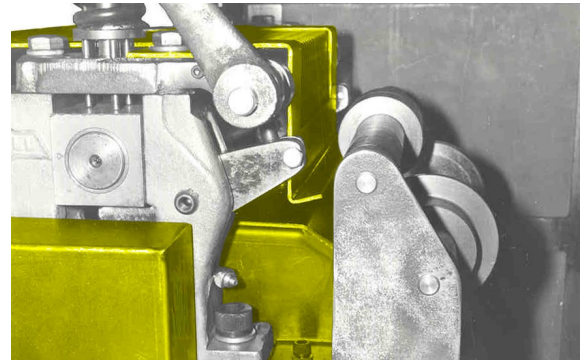
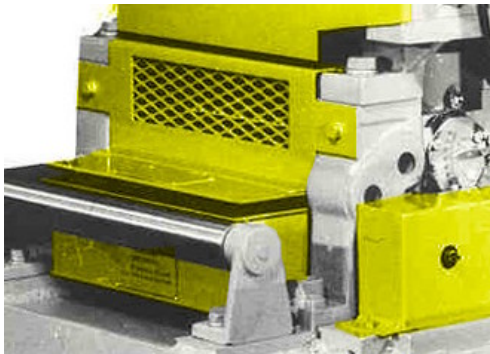

REVIEW PAGE 10 & 11 FOR GUARDING INFORMATION

## No. 4 Independent Feeding and Straightening Machine Guards:

**WARNING:**

Littell feeding machines with independent feed roll drive capability shall never be used to “TRIGGER” - “ARM” - “TRIP” or “CYCLE” a Punch Press or Shear. The feed’s electrical control interface signals shall only communicate that a feed roll has completed its rotation. When the feeder control receives a “begin feed signal” from a press or shear, it is assumed this signal is only given when it is safe to power rotate the feed rolls and when unsafe a “stop” signal will be given.

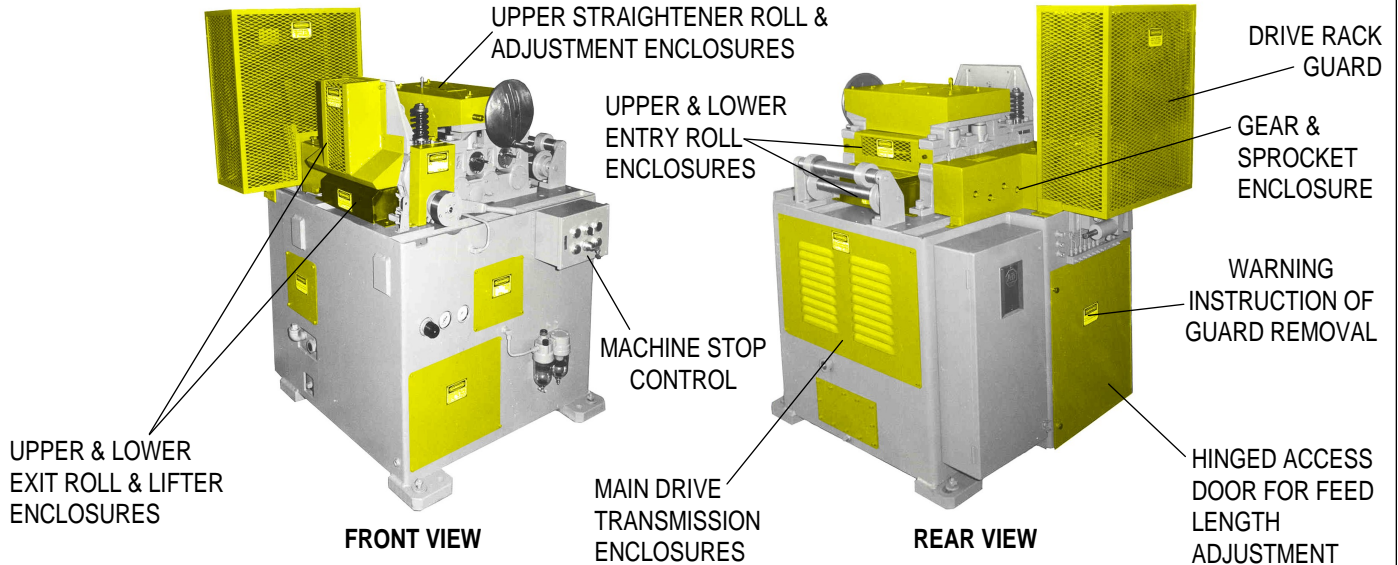

**ENLARGED GUARD VIEWS**

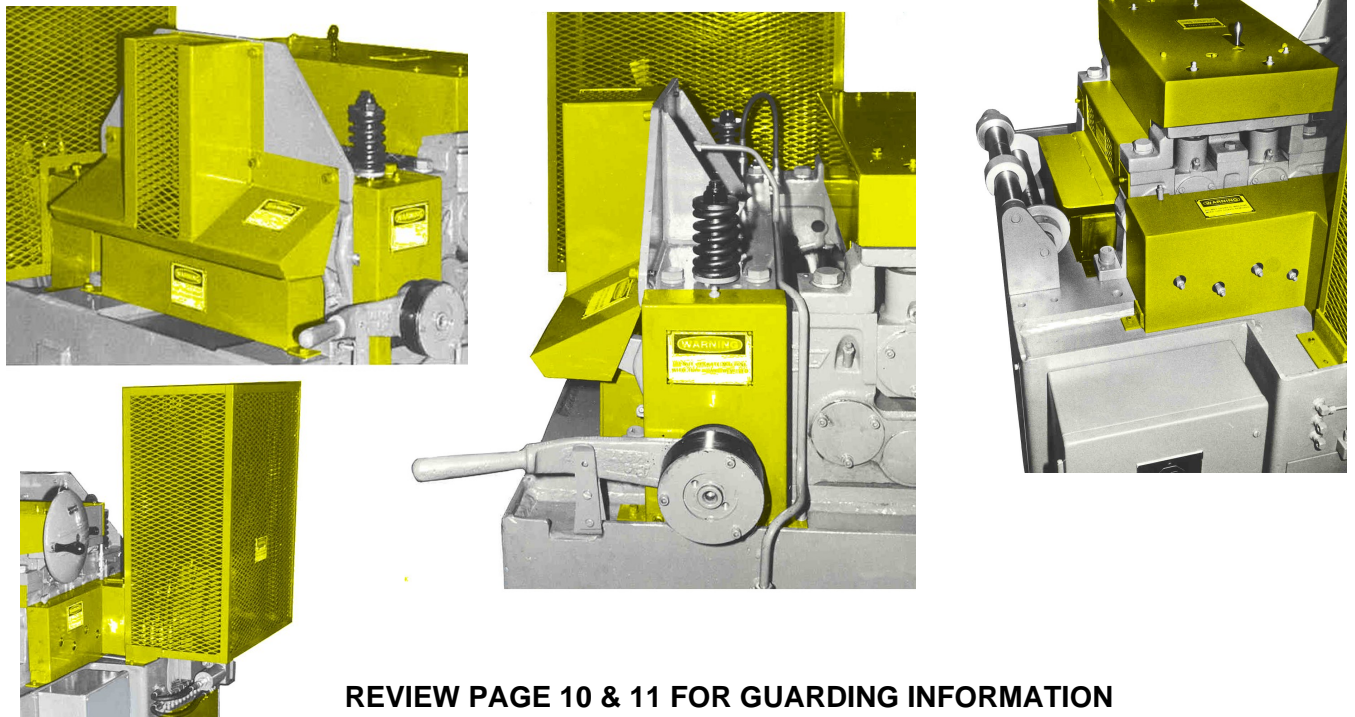

## No. 6 Series Straightening Machine Guards:

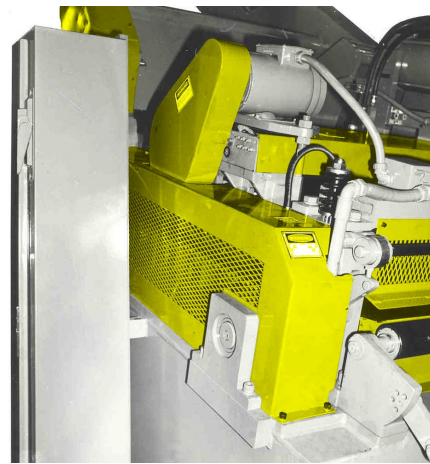
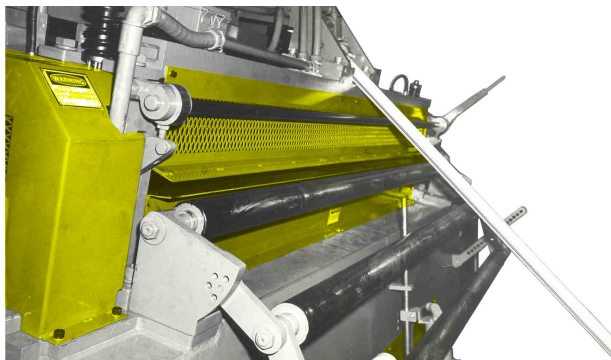
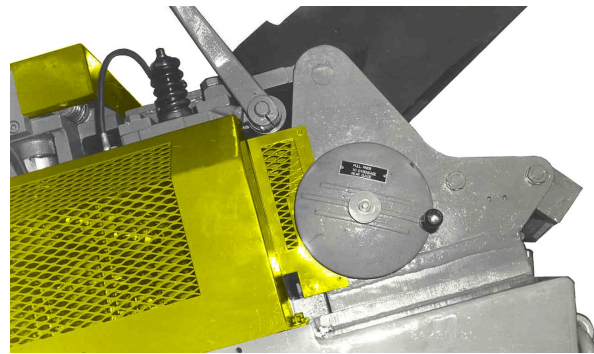
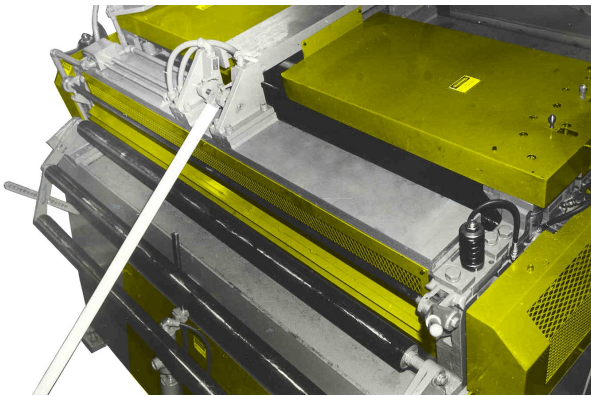
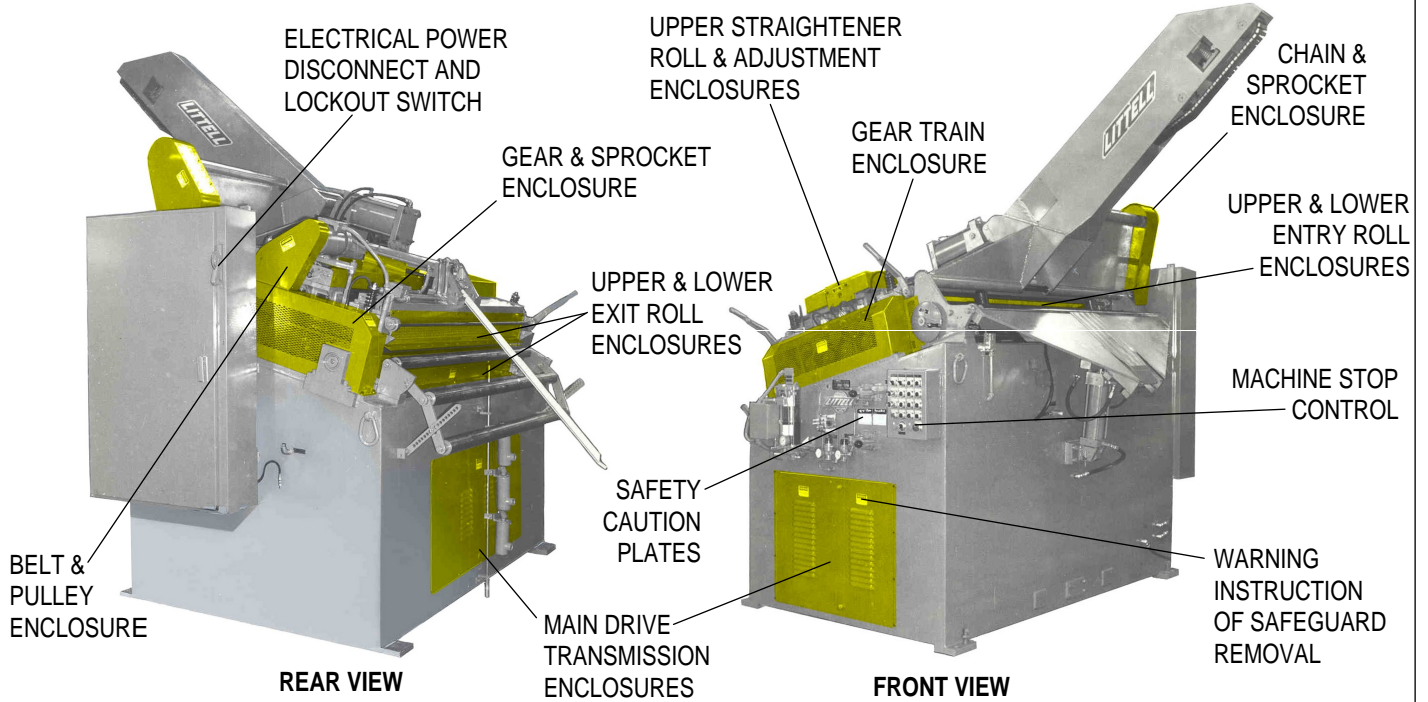

REVIEW PAGE 10 & 11 FOR GUARDING INFORMATION



## No. 8 Series Straightening Machine Guards:

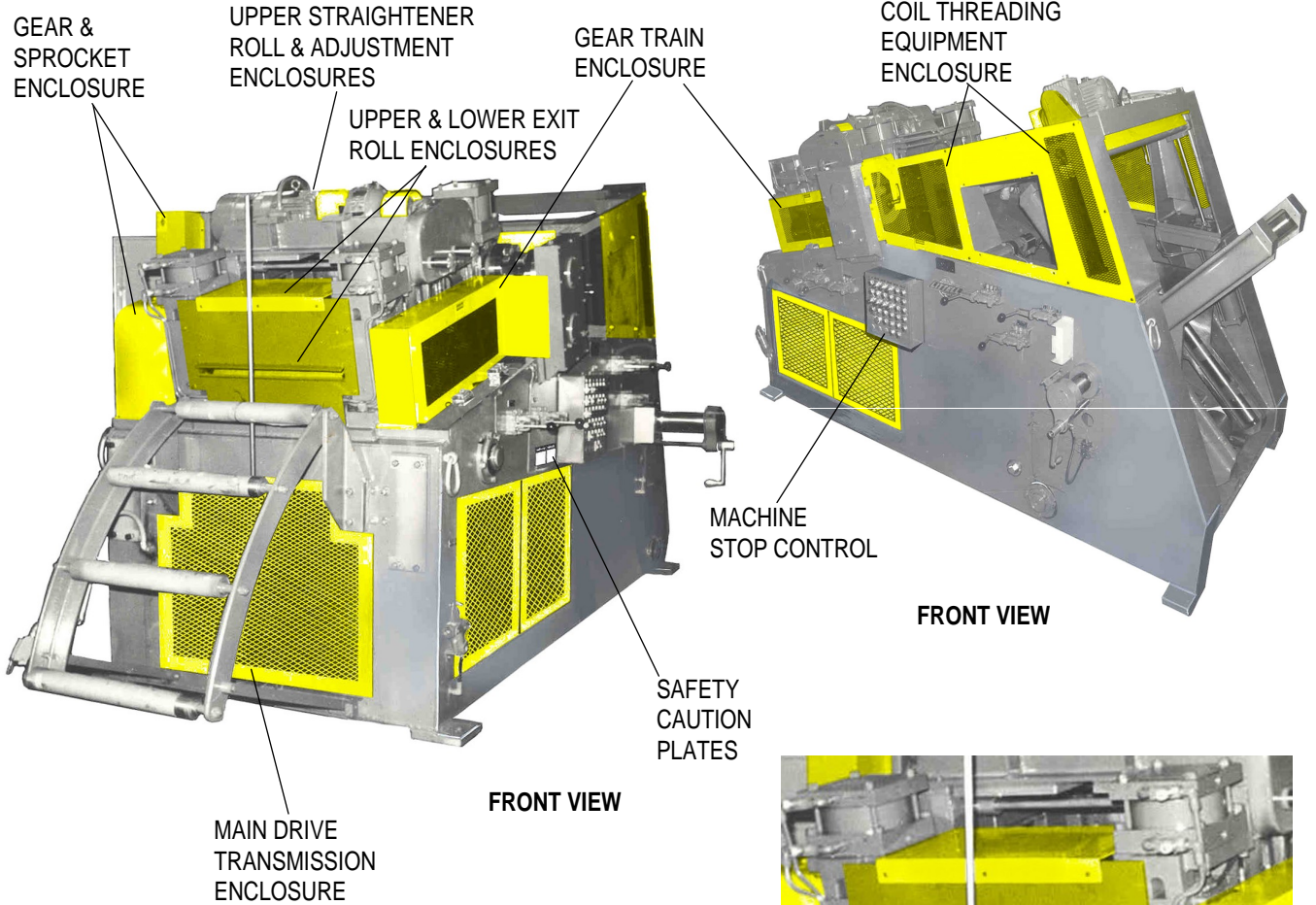

### ENLARGED GUARD VIEWS

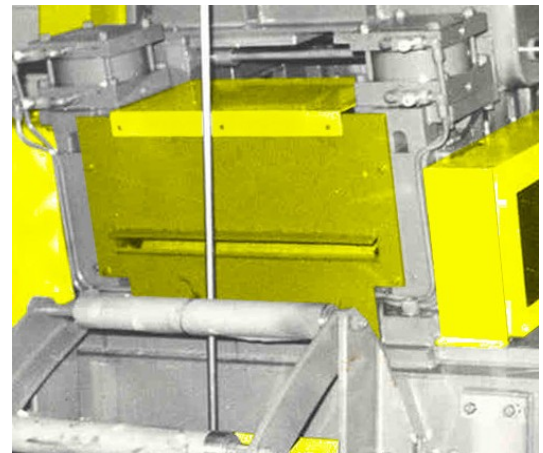

REVIEW PAGE 10 & 11 FOR  
GUARDING INFORMATION

## Guard Application, Design & Construction:

### APPLICATION

Special attention must be given to safeguarding all machine rollers which work and propel the material. Present trends indicate that these rollers are high risk and hazardous. They can cause severe injury to fingers, hands and arms of person attempting to unsafely clean or thread material while rollers are in motion.

Fixed roll enclosures, allowing passage of material only, must be permanently mounted to the main frame of the machinery and require the use of tools for their removal. These enclosures must prevent access to the roller hazards generally referred to as NIP, PINCH, or SQUEEZE points.

If a special application requires frequent access to the machinery rollers (CONSIDERED RARE), interlocked enclosures must be incorporated. They must create and maintain a "MACHINE SHUTDOWN" and prevent roller rotation whenever the enclosure allows access to the roll hazards.

Standard and special machines contain many varieties of optional devices and accessories which are positioned near the entry and exit rolls. Independently powered auxiliary equipment may be combined with these rolls creating unusual circumstances. When these situations exist, additional customized safeguarding may be required. Users must become familiar with their various local, state, and federal laws requiring machine safeguarding and should review the National Safety Council's machine guarding literature for assistance in identifying and guarding these possible hazards.

All parts straightening applications must incorporate all safeguarding to prevent acidulate injury. Applications of "hand feeding" parts into straighteners must be reviewed by users to insure the following safeguards are applied.

Part support entry tables and safeguards are required which only allow the operator to present parts to the table and push the part until roll engagement. They must prevent the operator from handling, supporting, or guiding the part immediately after entry roll engagement or during any time in which the part is propelled by the machine.

Part alignment, guiding, or support devices should not create a hazard. If these hazards are unavoidable, additional custom safeguarding is required such as safety hand tools.

### SUGGESTED DESIGN

Roll enclosures must allow for the free passage of material but prevent hands and fingers from reaching the roll nip position. This nip or hazard position varies with roll diameter position and arrangement. The following illustrations and related chart specify Littell's roll enclosure shapes and their maximum openings for material passage for each machine, roll diameter and roll arrangement.

The material passage openings are funnel shaped to give structural rigidity and assist in directing and guiding the materials lead edge during threading and unthreading operations. Support tables are placed .125" below material processing position to prevent unnecessary contact.

### SUGGESTED CONSTRUCTION

Littell has made extensive use of 1" x 1" x 1/8" steel angle, 16 gage sheet metal and flattened expanded metal as basic materials as they are light in weight, comparatively low in cost, available and provide a smooth exposed surface.

The steel angle provides maximum structural strength. The 16 gage sheet metal provides enclosure ability and is easily formed into irregular shapes or contours. The expanded metal allows good visibility during strip thread up, observation of machine components and material during feeding operations. Maintenance and lubrication functions are aided as, oil gages, lubricant, and components requiring monitoring are visible through the expanded metal. Visibility is improved when the expanded metal is painted flat black.

All metal used in guard construction must be free from dangerous burrs and sharp edges. Expanded metal and sheet metal shall be securely attached to the frame of the guard by welding on center to center distance of 4" max. or less. Littell recommends welding as it is more suitable in withstanding the vibrations and other stresses associated with automatic punch press operations.

All joints of the framework shall be made equivalent in strength to the frame material.

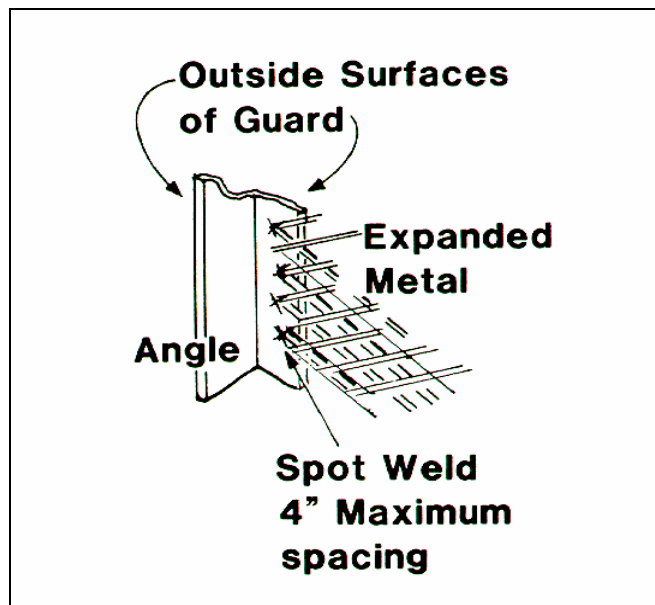

## Guard Application, Design & Construction:

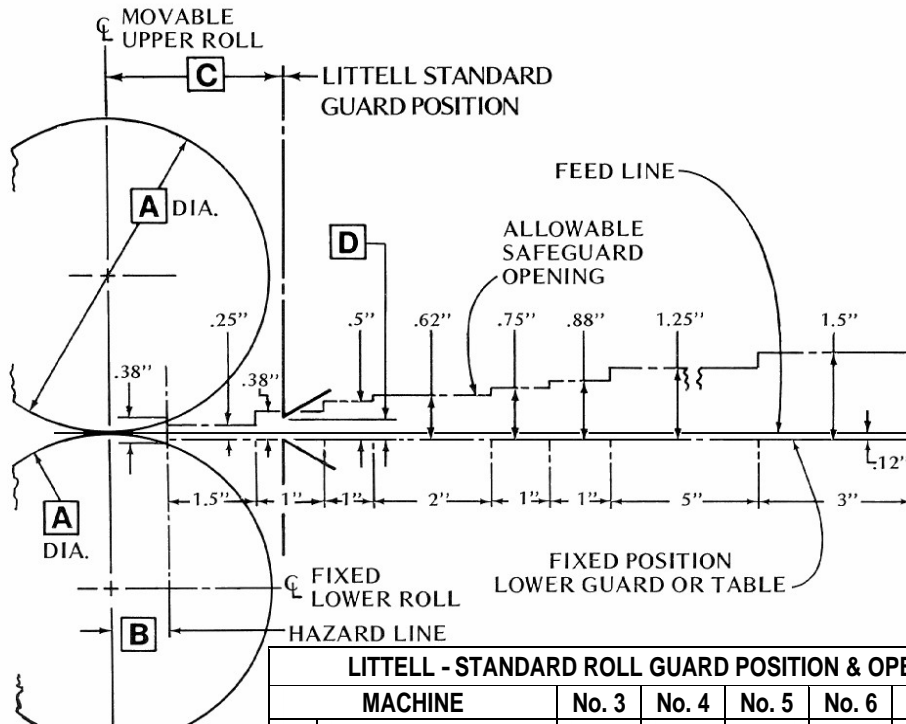

The maximum permissible opening for material passage and prevention of hand and finger access must comply with the specifications and intentions of this report and the roll guarding recommendations given in the National Safety Council's "Accident Prevention Manual for Industrial Operations."

LITTELL - STANDARD ROLL GUARD POSITION & OPENINGS						
MACHINE	No. 3	No. 4	No. 5	No. 6	No. 7	No. 8
A FEED ROLL DIA.	3.5	4.2	5.5	6.25	7.33	8.66
B HAZARD LINE	.81	.88	1.0	1.06	1.16	1.25
C GUARD POSITION	2.25	2.62	3.25	4.0	4.62	5.0
D MAX. OPENING	.31	.38	.38	.50	.56	.62

### COMMON GUARDING OBJECTIVES/GUIDELINES

The following is a list of guarding objectives and guidelines which should be utilized where applicable. All have been incorporated into the guards shown in this report.

- The roll enclosure is one of the most important guards on these machines and must be given careful consideration. After they're applied an inspection should be made to confirm if they actually prevent hand and finger access to the roll nip, pinch, or squeeze hazard points.
- The roll enclosure opening, restricted to allow passage of feeding material only, is funnel shaped to assist entry threading of the material's leading edge and provides structural rigidity.
- All operational handwheels, levers, and handles are accessible without requiring guard removal.
- Guards are permanently bolted to the machine and require tools for removal.
- Mechanical power transmission components are enclosed. Rotating pulleys, sprockets, shafts, couplings,

gears and moving belts chains, linkage, levers, and other hazardous components are guarded.

- Grease lubrication points are externally located to prevent the need for internal access to hazardous areas.
- The solid sheet metal formed enclosure prevents access to the lower roll and provides a smooth surface to support and guide the material.
- Expanded metal roll enclosure allows visual inspection of the roll surface.
- Shape and locate guards to clear and prevent containment of gages, regulators, valves, instruction tags or other operational controls that require frequent access and visibility.
- Each guard contains a Safety Caution plate warning not to operate the machine with the guard removed.

Safety Caution plates are located near the operational control station for easy recognition.

## Standard Safety Caution Plates:

In order to alert and remind everyone involved with this machinery of the hazards resulting from unsafe practices and procedures, the following signs should be applied by the user. Littell has mass produced and inventoried these standardized safety caution signs and is using them on our newly manufactured machines. Littell strongly recommends that users request and apply these signs to their Littell machines as soon as possible. These signs are not meant to frighten anyone; nor should they be interpreted to mean that the machine is unsafe. They should be permanently located and securely fastened nearest each machine's push button control station for immediate recognition.

Signs are OSHA Black and Yellow coated metal .062" THK. x 5.00" HIGH.

**CAUTION**

- **READ & COMPLY** with the Littell instruction manual before installing, using or servicing this machine.
- **NEVER** exceed the maximum machine capacities. Consult the Littell manual for capacity limitation and warnings.
- **NEVER** modify, alter or change the design, or intended use of this machine. If this machine does not meet your requirements, discontinue its use immediately and notify Littell.
- **BEFORE** servicing or repairing, always use proper tag and lockout safety procedures to exhaust, disconnect, and control all hazardous energy and motion, both entering or contained within this machine.
  - **NEVER REMOVE OR DISFIGURE THIS PLATE**

PLATE NO. 145897  
LITTELL

General Plate No. 145897

**CAUTION**

**HAZARDOUS AREA-READ FOLLOWING CAREFULLY.**

- **MAINTAIN SAFE CLEARANCE:** Machine starts automatically at any time by remote control.
- **NEVER** Rely on the strip loop position control to maintain a machine stop condition: Disconnect it's power supply.
- **BEFORE** and during operation make certain everyone is clear of the straightener, strip, coil and uncoiler.
- **NEVER** place your hands or fingers, with or without gloves on or near revolving rolls or moving strip for any reason.
- **NEVER** thread or enter a coil strip into revolving rolls.
- **NEVER** operate with any safeguard removed or missing. Discontinue using until all are replaced & functioning.
- **NEVER** leave machine operating unattended.
  - **NEVER REMOVE OR DISFIGURE THIS PLATE No. 147606**

LITTELL

Straightener Plate No. 147606

**CAUTION:**  
It is the user's responsibility to interpret and explain all safety precaution and signs to persons who do not read or understand English before they are allowed to use and care for Littell Machinery.

Inspect frequently to prevent signs from being hidden or covered and replace when defaced or significantly damaged.

The user should add additional signs to warn against hazards which result from other auxiliary equipment which he or others have combined with Littell Machinery.

**CAUTION**

**HAZARDOUS AREA-READ FOLLOWING CAREFULLY.**

- **MAINTAIN SAFE CLEARANCE:** Machine starts automatically at any time by remote drive control.
- **MAKE CERTAIN** the press or shear has been turned off, its flywheel stopped and the feed & cutter power supply disconnected & locked out before set up, servicing & repairing.
- **BEFORE** and during operation make certain everyone is clear of the cutter, press, feed, strip, straightener, coil and uncoiler.
- **NEVER** place your hands or fingers, with or without gloves, on or near revolving rolls or moving strip for any reason.
- **NEVER** thread or enter a coil strip into revolving rolls.
- **NEVER** operate with any safeguard removed or missing. Discontinue using until all are in place and functioning.
- **NEVER** leave machine operating unattended.
  - **NEVER REMOVE OR DISFIGURE THIS PLATE No. 147605**

LITTELL

Feed & Cutter Plate No. 147605

**CAUTION**

**HAZARDOUS AREA-READ FOLLOWING CAREFULLY**

- **MAINTAIN SAFE CLEARANCE:** Machine starts automatically by remote control.
- **STAY CLEAR** of Revolving Spindle, Keepers, Coil & Moving Strip.
- **LOAD ONLY** Stable, Banded or Retained Coils.
- **MAKE CERTAIN** this machine safely supports and controls the coil before removing the coil loading device.
- **NEVER OVERLOAD:** Excessive force applied by cranes, forklifts, or other loading devices may cause the loss of safe coil support and control. Inspect daily for machine damage and repair before using.
  - **NEVER REMOVE OR DISFIGURE THIS PLATE**

PLATE NO. 145896  
LITTELL

Uncoiler Plate No. 145896

## Safety Precautions:

### WARNING:

READ AND UNDERSTAND ALL OF THE FOLLOWING:

FAILURE TO COMPLY WITH ANY ONE PRECAUTION MAY CAUSE SERIOUS BODILY INJURY TO YOURSELF OR OTHERS.

ONLY PERSONS WHO THOROUGHLY UNDERSTAND AND COMPLY WITH ALL OF THE FOLLOWING SAFETY PRECAUTIONS ARE QUALIFIED TO SAFELY USE AND CARE FOR LITTELL MACHINERY.

- Read and comply with the straightening machine instruction manual before installing, using or servicing.
- Never exceed the maximum machine capacities. Consult the instruction manual for capacity limitations and additional safety precautions.
- Never modify, alter or change the design or intended use of the machine. If it doesn't meet your requirements, discontinue its use immediately and notify Littell.
- Before servicing, repairing, maintaining, or cleaning, always use proper tag and lockout safety procedures to exhaust, disconnect, and control all hazardous energy and motion, both entering and contained within this machine.
- Before using, read, understand, and comply with all safety warnings.
- Know the location and access to the emergency stop controls.
- Before using, know what machinery safeguards exist and their proper location.
- Never operate the straightener with its safeguards removed or missing. Discontinue using until all are replaced and properly functioning.
- Maintain a sense of personal safety awareness. Observe all safety warnings and practices. Be on the lookout for hazardous conditions. Report hazards and obtain instruction for their control from your supervisor.
- Before operating machinery, always make certain all persons are in a safe location.

- Stay alert; don't become careless or over confident. Avoid preoccupation, inattention, distraction and talking when loading and using and caring for this machine.
- Use personal protective equipment and clothing such as safety glasses, helmets, gloves, spats, shoes, and protective sleeves as required to suit the operation.
- Never wear clothing or jewelry that could cause part of the body to be caught or dragged into moving coil, strip or machinery.
- Follow only your instructed work procedures that you have been trained for. If a new or unfamiliar situation arises, ask your foreman for safe instructions before proceeding.
- Straighteners start automatically by remote control. Always maintain a safe clearance from the straightener and the entering and exiting coil strip.
- Standard straightener roll enclosures are permanently mounted and require tools for removal. They are not designed nor intended to allow rapid removal or frequent access to the rollers. If a special application requires such access, special safeguarding must be requested and installed that will cause an automatic "Shutdown" of the machine to occur and be maintained when the roll enclosure is removed or the safeguarded area is unsafely penetrated.
- Never position yourself under, above or in the direction and path of a coil strip.

PROHIBITED



**KEEP AWAY FROM  
REVOLVING ROLLS**

PROHIBITED



**NEVER CLEAN ROLLS  
WHILE REVOLVING**

- Never place your hands (with or without gloves) on a moving strip or skeleton.
- Never cross over or under operating equipment or the coil strip.

Continued on Page 14.

### Safety Precautions:(Cont'd)

- Never use the straightener control arm to remote strip loop sensing device as a manual hand control to start straightener rolls revolving while other persons thread strip into the entry rolls or perform services to the straightener.
- Before propelling coil strip through the straightener, make certain all persons are at a safe clearance from the moving strip, coil, and coil dispensing machinery.
- Never thread or enter a strip into revolving straightener rolls.

#### TO THREAD SAFELY - ALWAYS:

1. STOP THE MACHINE.
  2. OPEN ENTRY ROLLS.
  3. ENTER STRIP.
  4. CLOSE ENTRY ROLLS.
  5. REMOVE HANDS FROM STRIP.
  6. START MACHINE.
  7. INCH/JOG STRIP THROUGH STRAIGHTENER
- Never rely or depend upon the straightener control arm or remote loop sensing device stop control to MAINTAIN a machine stop condition.
  - Protect yourself and others from injury by never bypassing or eliminating any safety device, feature, or procedure.
  - Only qualified electrical, pneumatic or hydraulic personnel should work on respective circuitry.
  - Before and during servicing, repairing, maintaining or cleaning, always maintain a machine shut-down by tagging and locking out the electrical disconnect switch located on the straightener control panel or upon a nearby main power straightener supply source to prevent other persons from accidentally restarting the machine.
  - Always Tag, Lockout, Vent, and Exhaust hydraulic and pneumatic pressure that, as stored or trapped energy, could cause dangerous machinery motion.

- Always make certain all machinery components will maintain a safe position during all maintenance and repairs, by using adequate physical blocking, restraint, and control procedures. Never depend upon the machine's hydraulic or pneumatic power to hold or maintain any components in a constant position.
- Never leave the straightener unattended with the power turned on.

#### A SAFETY FIRST WARNING

It is impossible to foresee all possible uses, and applications of this machine. Therefore it is also impossible, to warn you in advance of every possible hazard, or to tell you that this machine will always be absolutely "hazard free". Your best protection against injuries to yourself or others is to always be cautious and remind yourself to think "SAFETY FIRST" before attempting any questionable, unfamiliar, infrequent, physical involvement with this machine that you have NOT been specifically trained for. When these situations arise, act cautiously, think "SAFETY FIRST", and protect yourself and others by requesting detailed safety instructions and related training from your management before attempting any such involvement for the care and use of this machine.

## DIRECTORY

### SAFETY LITERATURE / STANDARDS / REGULATIONS

The following is a list of some of the Federal Regulations and other safety literature which users should obtain and review before applying safeguards to Littell Products. Each publication has been cross referenced to some (but not necessarily all) of the areas in which they are involved. Many other publications exist (such as American National Standards) and can be easily identified in the "Sources of Standards" listed in the OSHA Federal Regulations below.

APPLICABLE SAFETY LITERATURE / STANDARDS / REGULATIONS	INVOLVEMENT AREA
"Accident Prevention Manual for Industrial Operations." By National Safety Council - Chicago, IL 60611	<ul style="list-style-type: none"> <li>● Complete Sourcebook for industrial safety.</li> </ul>
"Guards - Illustrated - Ideas for Mechanical Safety." By National Safety Council - Chicago, IL 60611	<ul style="list-style-type: none"> <li>● Machine guarding Methods and devices.</li> </ul>
Littell Safety Awareness Report No. SAR-100 - Unbanding Coils. Littell Safety Awareness Report No. SAR-101 - Safeguarding and Safety Precautions for Feeding Machines. Littell Safety Awareness Report No. SAR-103 - Safeguarding and Safety Precautions for Uncoilers. Littell Safety Awareness Report No. SAR-108 - Roll Cleaning Safety Precautions.	<ul style="list-style-type: none"> <li>● Specific safety instructions and safety precautions on the safeguarding, care and use of Littell products.</li> </ul>
OSHA - Part 1910 - Subpart D - Walking and Working Surfaces. SECTIONS: 1910.21 Definitions. 1910.22 General Requirements. 1910.23 Guarding Floor and Wall Openings and Holes. 1910.24 Fixed Industrial Stairs. 1910.25 Portable Wood Ladders. 1910.26 Portable Metal Ladders. 1910.27 Fixed Ladders. 1910.28 Safety Requirements for Scaffolding. 1910.31 Sources of Standards.	<ul style="list-style-type: none"> <li>● Access to Press Crank Shaft of Feeders - Drive Adjustments.</li> <li>● Protection from Floor Pits for Strip Loop Storage.</li> <li>● Access to "Hard To Reach" areas of large machinery for servicing or repairing.</li> </ul>
OSHA - Part 1910 - Subpart J - General Environmental Controls. SECTIONS: 1910.144 Safety Color Code for marking Physical Hazards. 1910.145 Specifications for Accident Prevention Signs and Tags. 1910.147 Sources of Standards.	<ul style="list-style-type: none"> <li>● Regulations for identifying and communicating hazards</li> </ul>
OSHA - Part 1910 - Subpart N - Material Handling and Storage. SECTIONS: 1910.176 Handling Material - General. 1910.178 Powered Industrial Trucks. 1910.179 Overhead and Gantry Cranes. 1910.184 Slings. 1910.189 Sources of Standards.	<ul style="list-style-type: none"> <li>● Safe care and use during service or repairs of machines.</li> <li>● Safe Coil Handling &amp; Loading.</li> <li>● Safe Scrap Handling &amp; Unloading.</li> </ul>
OSHA - Part 1910 - Subpart O - Machinery and Machine Guarding. SECTIONS: 1910.211 Definitions. 1910.212 General Requirements for All Machines. 1910.217 Mechanical Power Presses. 1910.219 Mechanical Power Transmission Apparatus. 1910.221 Sources of Standards.	<ul style="list-style-type: none"> <li>● Safeguarding of all machine hazards.</li> <li>● Mechanical Power Presses used with Littell Roll Feeds Safely.</li> </ul>
OSHA - Part 1910 - Subpart S - Electrical. SECTIONS: 1910.308 Application. 1910.309 National Electrical Code.	<ul style="list-style-type: none"> <li>● Safe addition of electrical interlocks.</li> <li>● Safe care and use of machinery with electrical power.</li> </ul>
American National Standard Institutes. Safety Requirements for the Construction, Care, and Use of Shears No. ANSI-B11.4.  American National Standard Institutes. Safety Requirements for the Construction, Care, and Use of Mechanical Power Presses No. ANSI-B11.1	<ul style="list-style-type: none"> <li>● Safe care and use when combined with Littell Products.</li> </ul>

Additional copies of this Safety Awareness Report are available and supplied free to all our product users when requested. We recommend that users place this report in existing Littell machinery instruction or service manuals which should always be readily available to everyone involved with this machinery allowing them to maintain familiarity with all safeguards, their purpose, location, and warnings.

If you should need additional information or copies contact the Littell Service Department.

Although this report is not a "SAFETY CODE OR STANDARD", the addition of safeguarding and adherence to the safety precautions contained in this report will assist users in complying with the existing Federal Regulations.

This Safety Awareness Report was produced and freely distributed because Littell cares about the safety of its product users. Please help reduce hazards and prevent accidents by complying with its instructions.

**LITTELL INTERNATIONAL, INC.**

145 SWIFT ROAD  
ADDISON, ILLINOIS 60101-1407, U.S.A.  
AREA CODE: (630) 916-6662  
LITTELL TELEFAX: (630) 916-6663  
SERV. DEP'T TELEFAX: (630) 916-6664

**special note:**

**LITTELL assumes no responsibility in connection herewith, nor can it be assumed that all acceptable safety measures are contained in this publication, or that other additional measures may not be required under particular or exceptional circumstances or conditions.**