

SUBJECT:

Safeguarding & Safety Precautions For LITTELL Spindle Uncoilers & Recoilers.

WARNING:

To prevent serious injury to persons involved with Littell Spindle Uncoiling & Recoiling machines, read and comply with all of the following safety instructions.

SAFETY INSTRUCTIONS:

Immediate action, by users of this machinery, must be taken to apply accident prevention safeguards and safety precautions as specified in this report. Due to today's high probability of employees receiving insufficient training or supervision combined with the possibilities of committing unsafe, careless or negligent acts, this precautionary action is mandatory.

To prevent serious injury to persons in your company, use the safety information contained in this report to assist yourself in accomplishing both the required addition and continued use of the necessary safeguards and safety precautions.

Throughout this report the word "USER" means any individual, partnership, corporation, or other form of enterprise which employs, contracts with, hires, benefits from, or is responsible for the persons who install, setup, adjust, operate, service, maintain, repair or work on or around machinery originally manufactured by Littell.

It is the Employer's responsibility to comply with the OCCUPATIONAL SAFETY & HEALTH ADMINISTRATION'S general industry standards, part 1910, Title 29 of the CODE OF FEDERAL REGULATIONS.

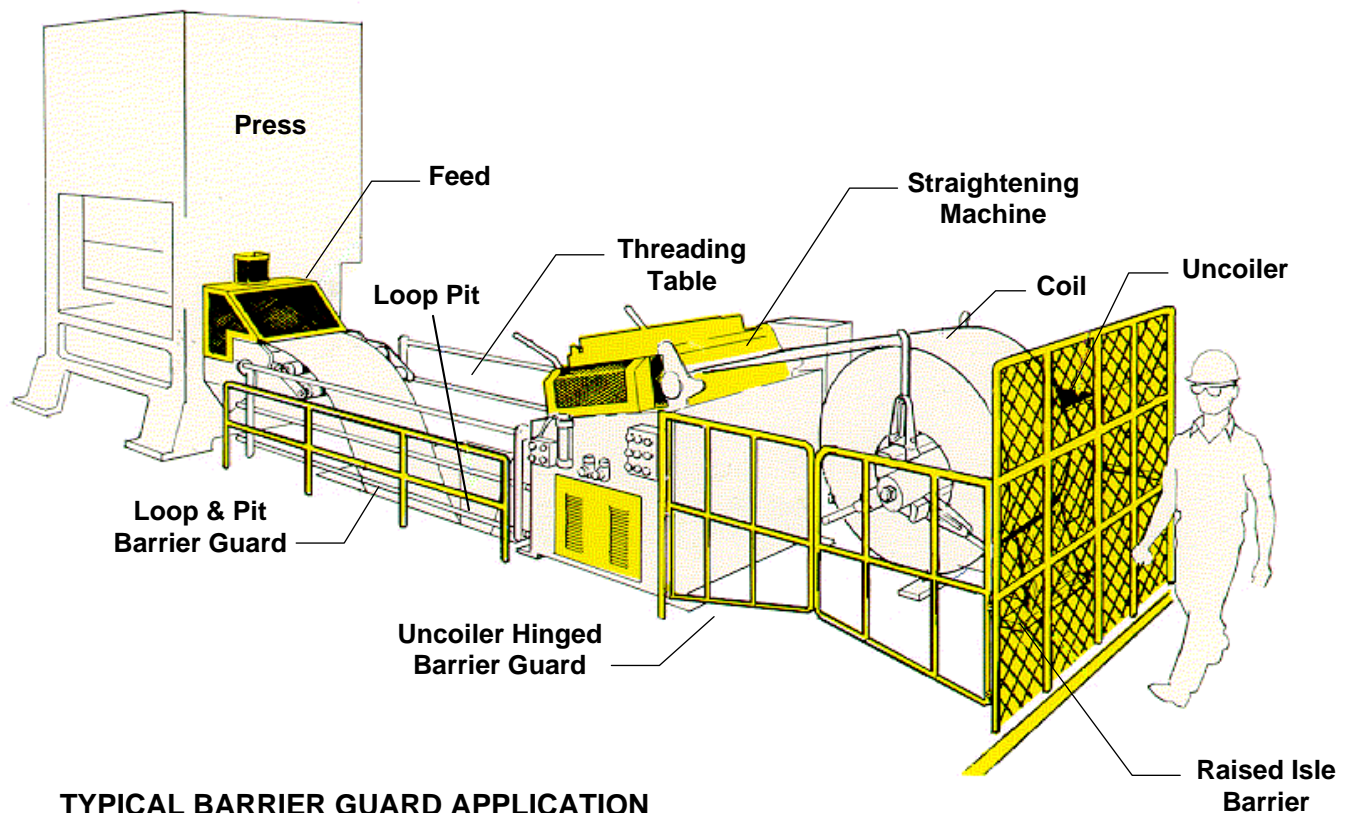

TYPICAL BARRIER GUARD APPLICATION

Safety Instructions: (Cont'd)

SAFEGUARDING:

Littell has manufactured numerous styles, designs, and sizes of Uncoilers & Recoilers for a wide variety of applications for over 50 years. When these machines and their applications are combined with the variety of options, accessories, plant or factory space, arrangement, auxiliary or nearby equipment, coil handling devices, loading/unloading methods, production pace, access isles, and frequency of involvement, it is easy to understand that standardized, mass produced, and immediately available safeguards from Littell are impractical. Safeguard designs will vary and must be tailored to each individual machine for each application.

The user must safeguard all coil dispensing, winding and material handling areas. These areas are high risk and hazardous. They can result in severe injury to persons due to their contact with rotating coil, spindle components, and the moving strip.

It is impractical to permanently enclose the uncoiling, recoiling, and coil handling areas. In most applications, frequent access to the machinery is required for a fresh supply or removal of coiled materials. These coils and their loading and handling devices require sufficient space to safely operate within. Therefore, the accessibility for coil transportation and safe maneuvering space must be considered before applying safeguards.

There are general areas which have common hazards and solutions for developing the general design of each safeguard. This report illustrates the design of typical safeguards required for these common areas and provides a guideline that can be used in manufacturing and applying them.

This report is not intended to illustrate every safeguard which may be required or to limit the application of safeguarding to those shown in this report. It is intended to describe some of the hazards which exist, to require safeguarding to eliminate or to minimize those hazards, and to define certain responsibilities.

Compare all the safeguarding illustrations in this report against your present uncoilers/recoilers and identify those areas which are inadequately protected, including existing safeguards which are defective. These areas must be given immediate attention in order to correct deficiencies and to accomplish the addition of the required safeguards by the user.

To effectively apply a safeguard it must be designed, manufactured, installed and used properly for each application; otherwise persons may seek to circumvent it. The user must become familiar with the various types of safeguards used throughout the industry and determine which type fits his application best and provides maximum protection.

To assist users in judging the safeguarding of machinery a "DIRECTORY OF SAFETY LITERATURE, STANDARDS, & REGULATIONS" has been included in this report. Users should obtain and review this material immediately.

Many manufacturers are equipped to furnish standard or special safeguards. A list of suppliers can be easily found in "BEST'S SAFETY DIRECTORY" of the

A.M. BEST COMPANY
AMBEST ROAD
OLDWICK, NEW JERSY 08858

TRAINING:

The use of cranes, hoists, hooks, slings, and power lift trucks, is subject to certain hazards that cannot be safeguarded by mechanical means, but only by the exercise of reasonable intelligence and care. It is therefore essential that the user restrict involvement of persons to only those who are competent, careful, physically and mentally fit, and thoroughly trained in the safe use of the uncoiler or recoiler and handling of the coils.

The addition of safeguards is not the sole remedy for accident prevention. To realize maximum protection benefits, the safety precautions in this report must be incorporated into user's safety training programs. Persons involved with Littell machinery must be supervised and tested to determine and continually insure that all have been adequately instructed by demonstrating, with discrete repetition, their awareness and understanding of these safety precautions including other applicable safety practices, codes, standards, and regulations which are not included in this report.

Many accidents have occurred due to a supervisor's lack of training; because of this lack of training, the supervisor is incapable of developing the necessary safety awareness and cannot transfer safe work procedures to others.

Users must make certain that only persons who understand Littell machinery, its intended use, care and safety requirements and who are able to communicate this knowledge be given the

Safety Instructions: (Cont'd)

TRAINING: (Cont'd)

responsibility of instructing; training and supervising others involved with this machinery.

It is the user's responsibility to interpret and to explain all safety precautions and signs to persons who do not read or understand English **BEFORE** they are allowed to use and care for this machinery.

WARNING:

ONLY PERSONS WHO THOROUGHLY UNDERSTAND AND COMPLY WITH ALL OF THE GIVEN SAFETY PRECAUTIONS ARE QUALIFIED TO USE AND CARE FOR LITTELL MACHINERY WHICH HAS BEEN SAFEGUARDED AS INSTRUCTED IN THIS REPORT. MAKE CERTAIN THESE PRECAUTIONS ARE APLIED IMMEDIATELY.

The user must decide what personal protective safety equipment is required to perform each job safely. Items such as safety glasses, shoes, gloves, helmets, spats, protective sleeves and material handling equipment are common in the metal working industry.

USER'S SAFE APPLICATION:

The operational requirements that are interfaced between uncoiler or recoiler, coil, loading and unloading equipment, and its handlers are frequently overlooked or unaccounted for; therefore, unsafe work procedures and practices result. Many of these practices are allowed to continue in today's industry because both users and handlers are unaware of the hazards and risks.

The intent of the following is to alert the user to the loading and unloading requirements which exist, to create an awareness of how they relate to safety, and to limit the selection and use of loading and unloading devices.

There are fewer recoilers in industry than uncoilers, but regardless of their differences in design and usage, the same safety awareness concerning coil handling and both spindle loading and unloading must be exercised by the user. The user must also apply equivalent safeguarding and safe application requirements.

The user must make certain all uncoilers and recoilers are sufficiently fastened to their foundations before loading or using. The practice of loading and using these machines without foundation fastening is unsafe. Without fastening, these machines and their coils can dangerously fall over. In addition, they can easily lose their required alignment during loading, uncoiling, and recoiling causing unsafe operation.

The user must limit the operation of the uncoiler or recoiler to the original manufacturer's rated capacities and the original design's intended use.

The coil size and weight limitation shall never be exceeded. The coil load must be properly positioned on the spindle to prevent overload and damage resulting in a loss of safe reliability. The user must make certain that the front coil retainers are used and applied per the loading sequence specified in this report.

The user must make certain the spindle expansion range is correct for sufficient and safe clearance during loading and unloading and expands enough to maintain a tight grip on the coil eye. The machine's ability to operate safely at the user's required maximum production speed must be closely analyzed by the user to be certain that the uncoiler or recoiler can perform without exceeding its own spindle load capacity (coil weight and strip tension) and can safely stop coil and spindle rotation without creating a dangerous condition.

Inferior application judgment and improper use of material handling equipment combined with hazardous loading/unloading methods and unsafe banding/unbanding work practices result in fallen coils and crushed limbs of nearby persons.

Special attention should be given to existing use and future selection of coil support, lifting and transporting devices. Their selection and use must always maintain control and stability of the coil. These selections and usage must safely allow for the coil variables such as size, weight, shape, internal stresses, tight or loose wound wraps, and also its variable application of straps, retaining bands, protective coverings, containers, skids, and method of storage.

To assist users in judging the safe selection, application and use of material handling machinery, obtain and review the literature in this report's directory.

Safety Instructions: (Cont'd)

USER'S SAFE APPLICATION: (Cont'd)

Both, batches (multiple coils) and individual coils that are large in diameter and narrow in width, are dangerous to handle. Transporting, lifting, and support devices which always "RETAIN" the coil or coils is preferred over devices which depend upon "BALANCE".

Example:

Slings through the coil eye
vs. "C-Hooks".
Coil Cars with Side Stabilizers
vs. Fork Trucks.

Hooks can be safe when used properly so as to always maintain a balanced load. Each transport, lifter and support device has its own advantages and disadvantages. Their selection must be based on which gives the best protection for each application. If the device selected depends on the balance of the coil, then throughout all coil handling and loading, the device must be "restricted" to that use which always maintains a balanced coil.

To safely load or unload, material handling equipment selection and use must be capable of performing the following sequences.

SAFE LOADING SEQUENCE

1. Prevent spindle from automatically rotating.
2. Remove spindle arm front coil retainers.
3. Contract spindle arms to safely clear coil eye and coil tail.
4. Release spindle brake.
5. Before lifting the coil, radially position the loading device in relation to the coil tail so both will clear the spindle arms.
6. Safely position a retained and stable coil in front of the spindle - DO NOT LOAD ON SPINDLE - compare exact location of loading device and tail in coil eye with location of spindle arms.
7. Radially position spindle arms to clear coil loading device and coil tail.
8. Position coil eye concentric with center of spindle.
9. Cautiously spear coil eye by slowly moving the coil and position against rear retainers without shock impacting. Continue to support coil on loading device.

10. Apply and lock all front coil retainers against coil.
11. Lower center of coil eye just slightly below center of spindle. Continue to support coil on loading device.
12. Expand spindle and slowly lift coil weight off the loading device just prior to full spindle engagement within the coil eye. Continue to expand until all arms are securely against coil.

WARNING:

IF COIL IS POSITIONED TOO HIGH – DO NOT OVERLOAD BY EXERTING SPINDLE EXPANSION PRESSURE AGAINST THE LOADING DEVICE – REVIEW SEQUENCE 11 & 12.

13. Establish clearance of loading device and remove safely.

SAFE UNLOADING SEQUENCE

1. Prevent spindle from automatically rotating.
2. Safely position and secure the coils strip end.
3. Apply coil retaining bands to help contain and stabilize coil.
4. Withdraw any auxiliary equipment from coil.
- 4A. Release coil tail clamp if present.
5. Release spindle brake.
6. Radially position spindle arms and coil tail to clear coil unloading device.
7. Apply spindle brake.
8. Position unloading device to receive coil weight.
9. Slowly contract spindle assembly to lower the coil weight on the unloading device.
10. Contract spindle to safely clear coil eye and coil tail.
11. Inspect coil and unloader for safe coil support and stability.
12. Unlock and remove spindle arm front coil retainers.
13. Cautiously remove coil from spindle and transport to a safe storage area.

The user must make certain this loading/unloading sequence is followed by reviewing all of his present practices of loading and unloading Littell Uncoilers and Recoilers. Corrections should be made where necessary to comply with the intent of this sequence.

Safety Instructions: (Cont'd)

USER'S SAFE APPLICATION: (Cont'd)

The user must prevent industrial trucks from being applied which do not have safe control of large diameter narrow width coils and other potentially unstable coils during spindle loading/unloading. The user must also prevent trucks from blocking or restricting safe access to both the uncoilers or recoilers expansion manual hand crank and the ability to safely apply the spindle arm coil restraints.

Cranes, hoists, and other lifting devices should have the ability to power traverse with precision or slowly move the coil laterally for accurate positioning when hazardous conditions require. Material handlers must never manually push upon a dangerously balanced coil and loading device to develop a coil and crane traverse momentum. The amount of momentum may become uncontrollable and unsafe for handlers to manually stop and prevent a collision or fallen coil. These unsafe conditions can be eliminated by restricting persons from the immediate coil handling and loading area. Handlers can safely position coils while operating the loading device from a remote location. Improper equipment application and practices which cause swinging, slingshot, or other unsafe movement of the coil and loading device must be eliminated.

Cranes, hoists and other lifting devices must be given careful consideration. They should be of sufficient capacity for the maximum load they will encounter. However they should not be of excessive capacity so that they significantly reduce their sensitivity. Even if uncoilers or recoilers are designed to withstand greater loads than their specified ratings, coils of less weight and their lifter support devices become easily deformed and dangerous in themselves when overloads develop by exerting excessive lifting pressure against a spindle.

Cranes, hoists and other lifting devices must be able to slowly and accurately position the coil eye concentric with the spindle. Without this ability, it is difficult to position the coil without causing a collision against the spindle. When the coil is spaired by the spindle and is raised "too high" and "too fast", overloads develop against the spindle, coil and its support device. Loss of coil stability and damage to equipment can result. A coil could

explode and telescope creating a sudden and hazardous condition.

The spindle and loading device can be severely damaged from overloading to the extent that they become hazardous if use continues without repair to their original reliability. The spindle and loading device should be frequently inspected for damaged components and when discovered, repaired before using.

The safe application of coil handling not only includes the proper selection of equipment but also requires planning of how and where the coils are stored so as to allow the equipment to be used as intended. Accessibility of each coil, the capability of making appropriate and safe contact between coil and loading devices, and their relationship with and effect upon a safe production pace are to be accounted for by the user.

Many problems can be eliminated by establishing a secondary coil support, storage, and orientation station. These stations allow handlers to, work at a safe pace, to determine direction of coil wind and location of edge burr and to clean the outer wraps of the coil when necessary.

When handlers have the time and opportunity to inspect and prepare for correct lifter attachment to the coil prior to an uncoiler reload demand, safer conditions develop as compared to trying to accomplish these tasks in a hurried manner which results from pressure of the uncoiler waiting unproductively for its fresh coil.

Coil banding or restraints are required on coils to confine its contents and maintain its physical characteristics during loading or unloading. Coils exist in an infinite number of conditions. These vary from internal stresses, irregular shapes, loosely wound wraps, and its center of gravity. These conditions seriously affect the coil's stability.

Handler's visual inspection can not determine these conditions in order to predict the coil's probability of maintaining its physical conditions when subjected to transporting and loading or unloading operations. It is common practice for handlers to assume coil stability and take unnecessary risks when loading or unloading unbanded coils. Users should take precautions to prevent these dangerous practices. For additional information concerning safe unbanded coils review Littell Safety Awareness Report No. SAR-100.





Safety Instructions: (Cont'd)

USER'S SAFE APPLICATION: (Cont'd)

COIL HANDLING USING "C-HOOK" LIFTERS

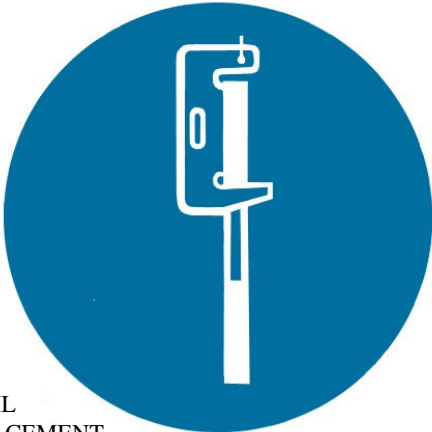
WARNING

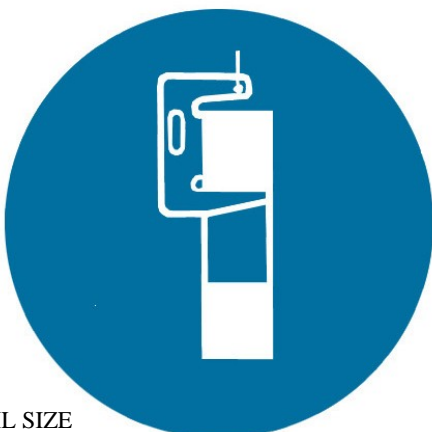
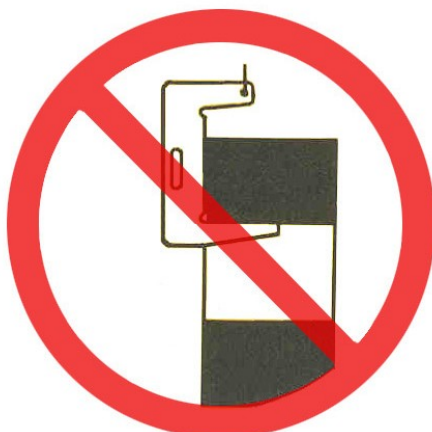
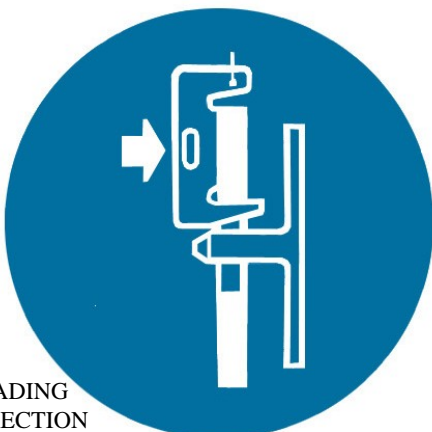
To prevent injury to material handlers and other persons due to coils falling from C-hook lifters, users must make certain that safe coil placement, size limitation, and loading direction is practiced as a minimum requirement per the following instructions.

REQUIRED	PROHIBITED	HAZARD
 <p>COIL PLACEMENT</p>		<ul style="list-style-type: none"> • Unsafe Coil Support. • Unbalanced Coil. • Unsafe Placement.
 <p>COIL SIZE</p>		<ul style="list-style-type: none"> • Hook Overload. • Oversize Coil. • Unbalanced Coil. • Undersized Hook.
 <p>LOADING DIRECTION</p>		<ul style="list-style-type: none"> • Reverse or Backward Loading Direction. • Coil & Spindle Collision. • Resting & Balancing Coil on End of Spindle When Removing Hook.

#3 Single Motor Driven Uncoiler Guards.

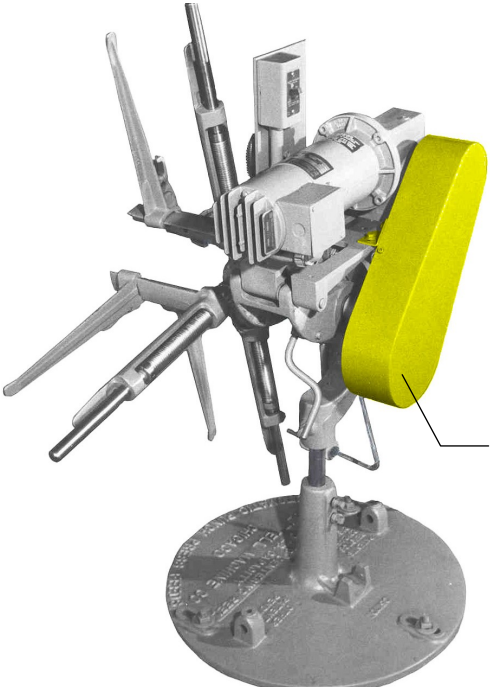
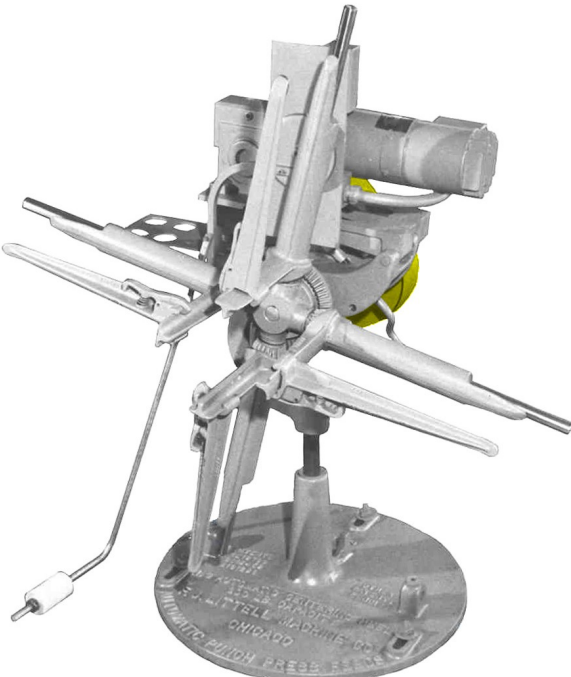

**DRIVE
BELT &
PULLEY
GUARD**

#5 Single Motor Driven Uncoiler Guards.

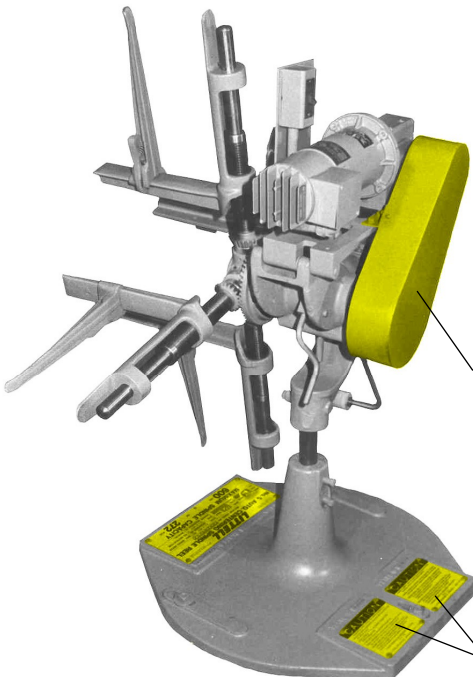

**DRIVE BELT
& PULLEY
GUARD**

**SAFETY
CAUTION
PLATES**



**MACHINE
CAPACITY**

#10 Single Motor Driven Uncoiler Guard.

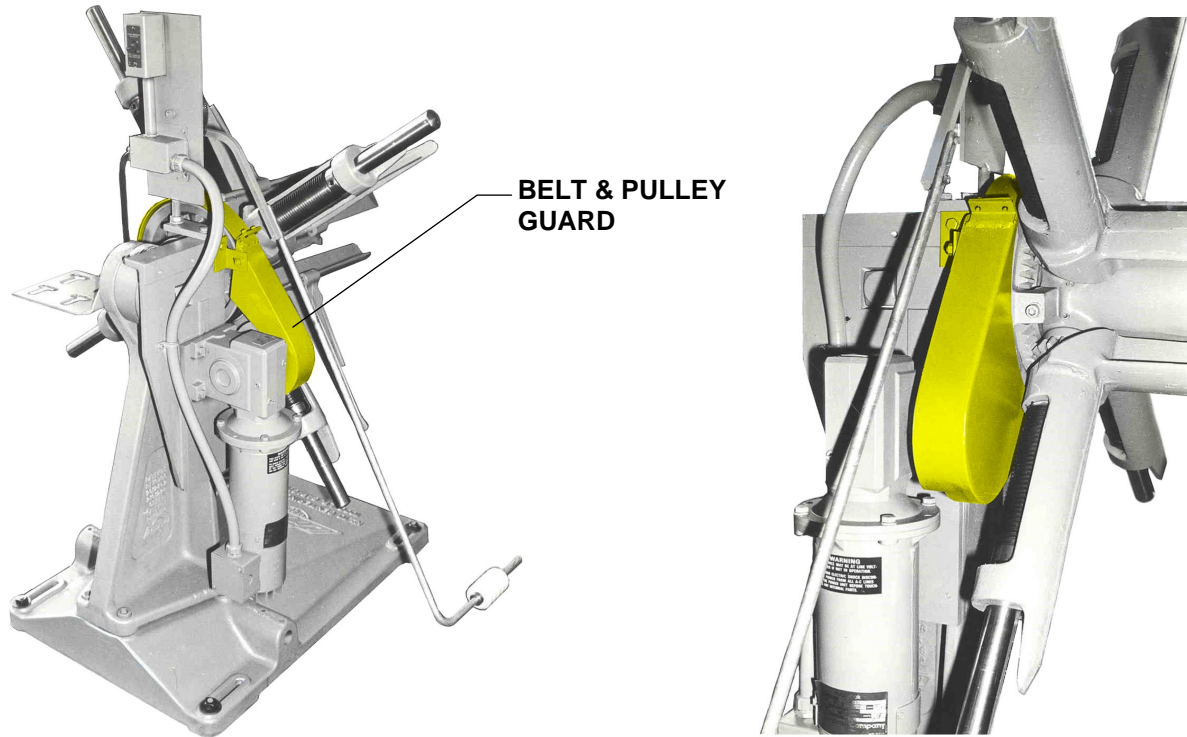

#10 Double Motor Driven Uncoiler Guard.

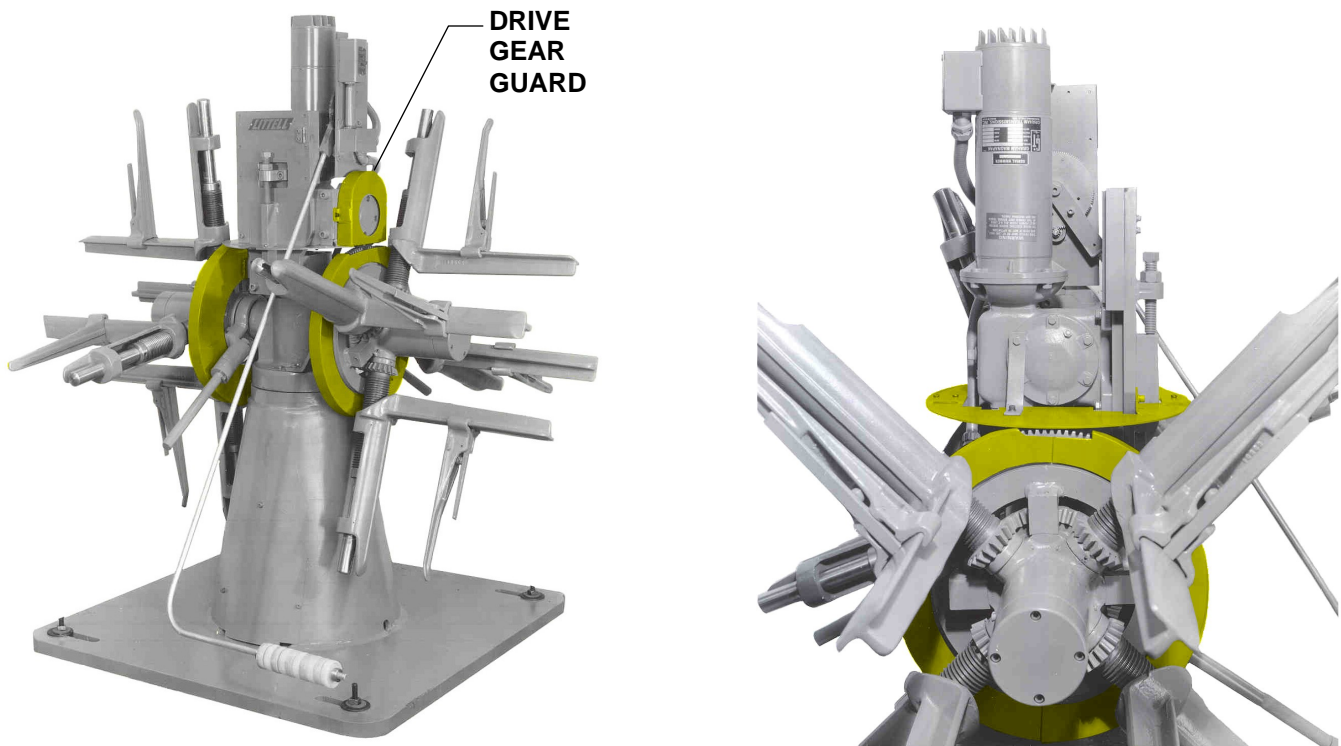

#25 Single Motor Driven Uncoiler Guard.

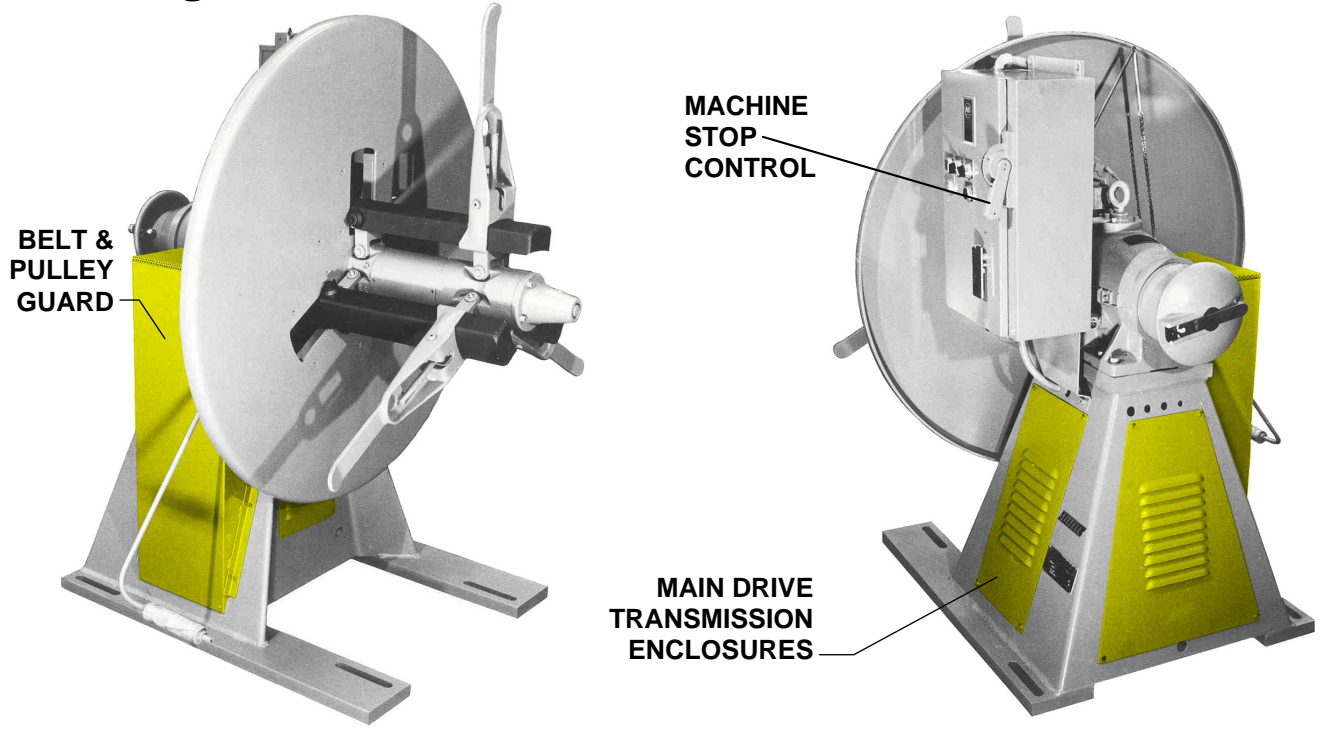

#40 Single Motor Driven Uncoiler Guard.

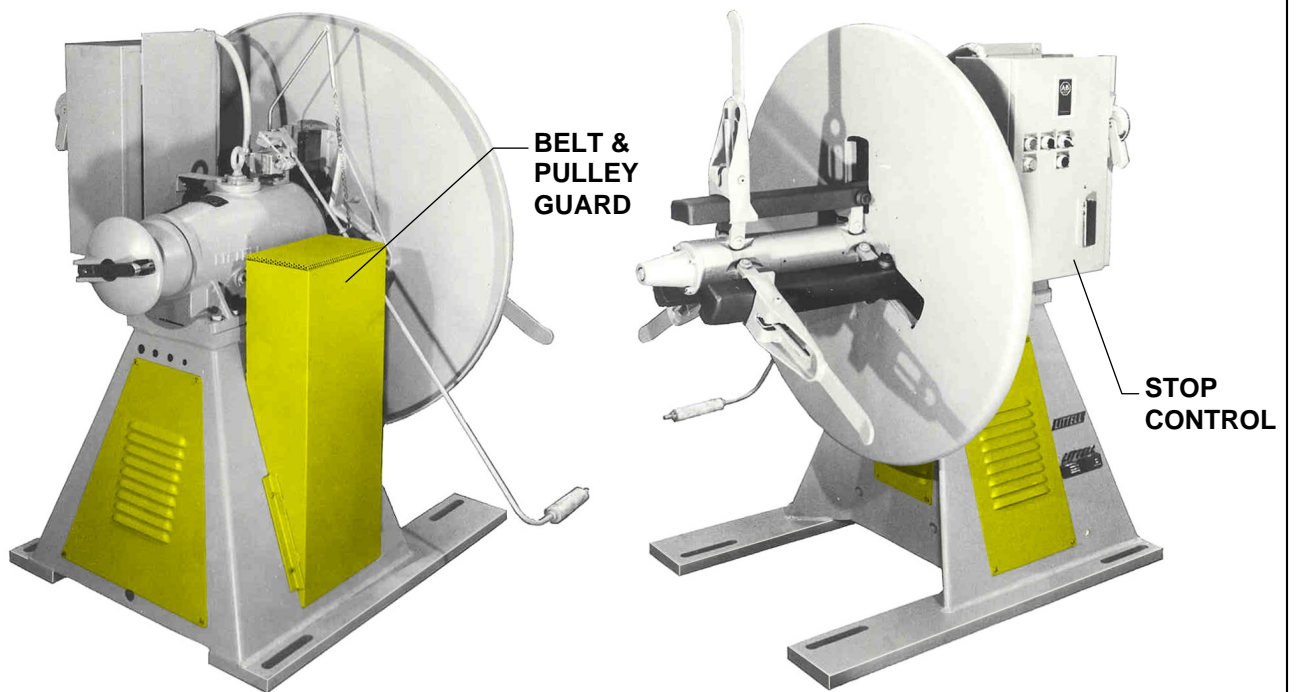

#60 Single Motor Driven Uncoiler Guard.

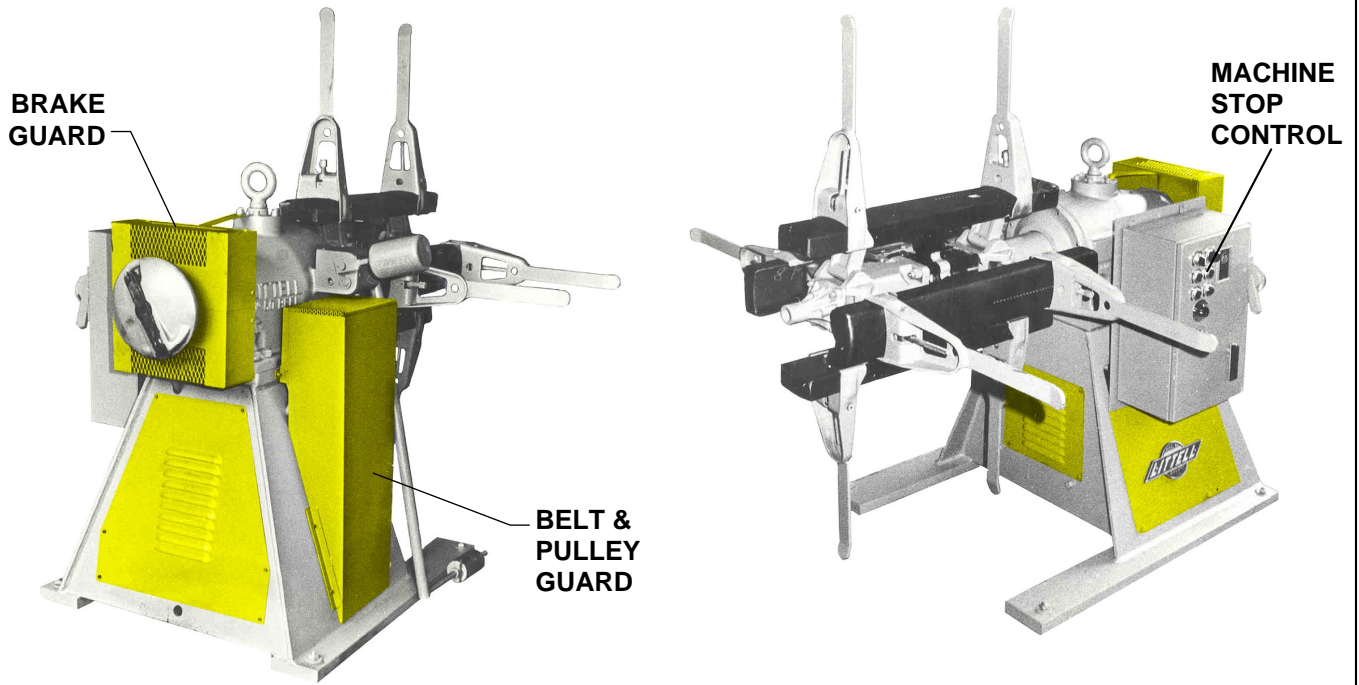

#60 Single With Inching & Power Expansion Uncoiler Guards.

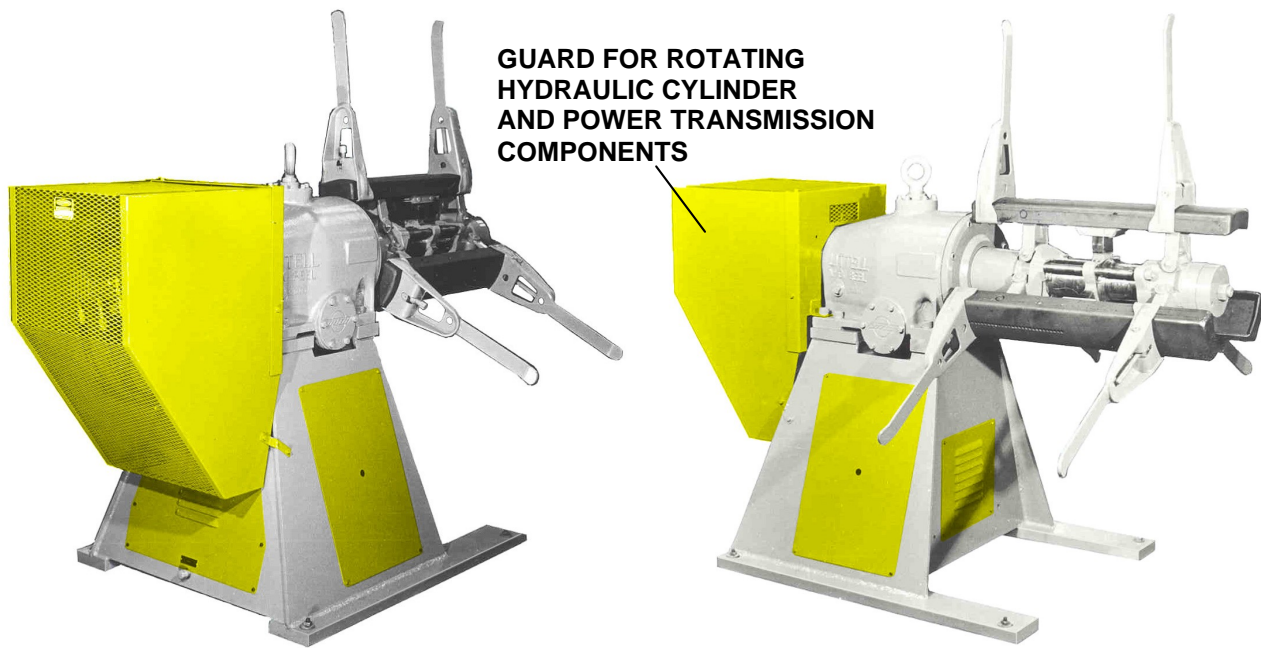

#90 Single Motor Driven Uncoiler Guards.

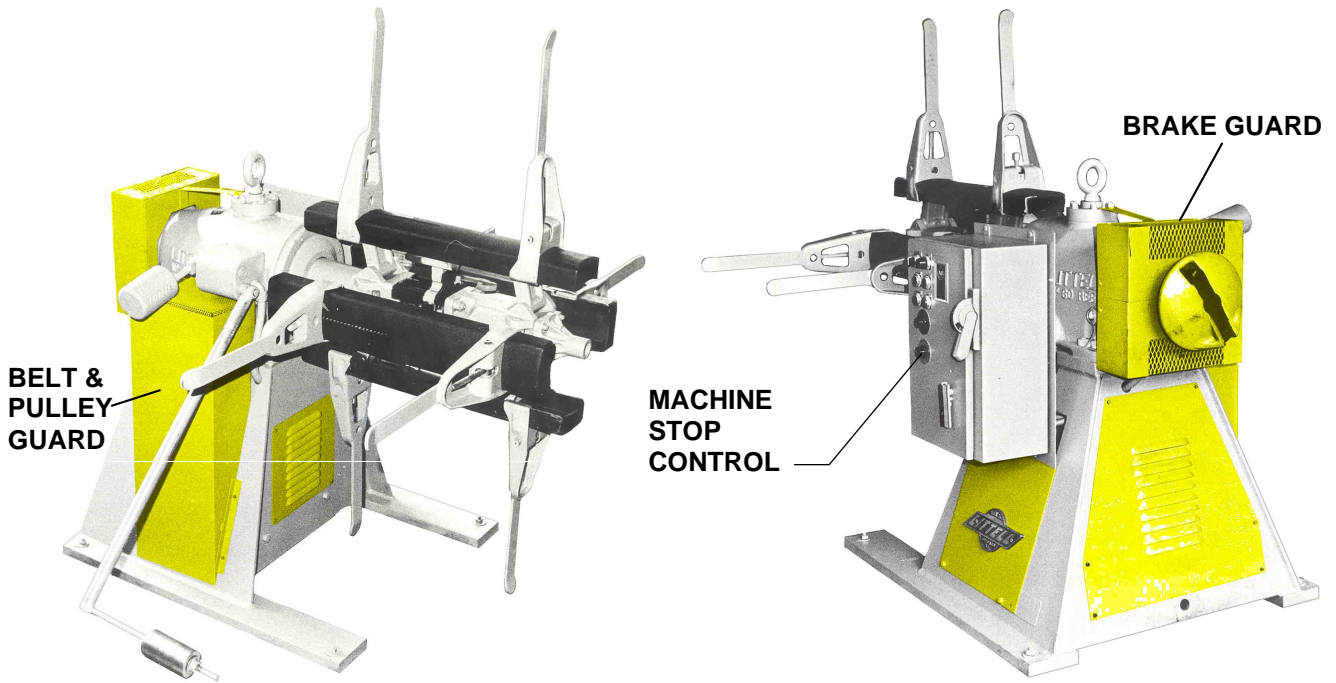

#90 Single With Inching & Power Expansion Uncoiler Guards.

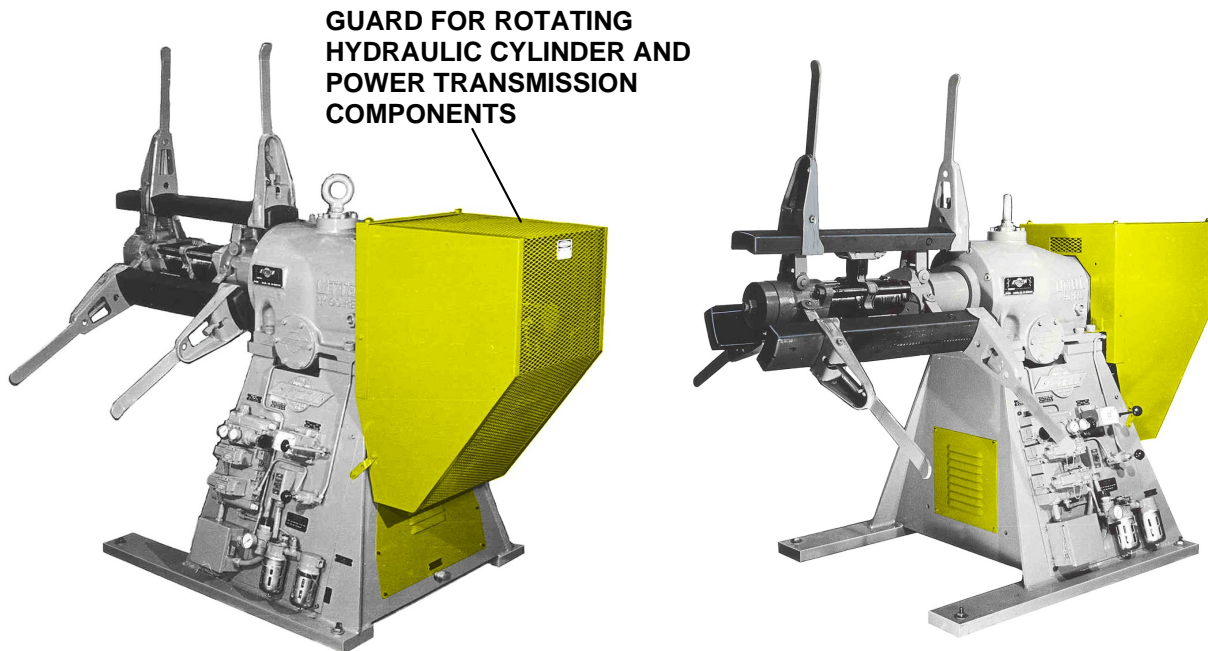

Guard Application, Design & Construction:

APPLICATION:

Hazardous power transmission components and other moving machinery or components must be safeguarded. Fixed enclosures or barriers which prevent access must be permanently mounted and require the use of tools for their removal. These enclosures or barriers must prevent access to the hazards generally referred to as NIP, PINCH, or SQUEEZE points.

If a special application requires frequent access to the machinery (considered rare), interlocked sensing and activation must be incorporated into the safeguard. They must create and maintain a "MACHINE SHUTDOWN" and prevent machine operation whenever the safeguard allows access to the hazard.

Standard and special machines contain many varieties of optional devices and accessories which are positioned near each other creating hazardous areas between themselves. When these situations exist, additional customized safeguarding may be required which is not available from the original manufacturer or each of the options or accessories. Users must become familiar with various local, state, and federal laws or codes requiring machine safeguarding and should review the National Safety Council's machine guarding literature for assistance in identifying and guarding these possible hazards. Refer to this report's directory for the identification and source of some of the materials.

Area or zone safeguarding is a practical method for preventing access to the coil handling, loading and uncoiling or recoiling areas. Heavy duty, permanently positioned fences or railings, with interlocked sensing gates or movable barriers, have been successfully applied without reducing safety or productivity. These area safeguards must be positioned to clear the material handling and loading devices as normal daily transport of coils could become dangerous if such safeguards become obstructions. The uncoilers or recoilers front and rear coil retainer and rotating coil must be safeguarded by area guarding.

Littell recommends special attention be given in locating area guards (fences, railings, barriers, etc.) throughout the entire coil processing system of machinery to prevent persons from easily contacting the coil strip wherever accessible. If these areas require frequent access for "set up -

threading - adjusting or similar requirements", interlocked guards are to be applied.

Warning signs should be applied to inform persons of the results of penetrating these area guards. Special heavy duty barriers are required when explosive coils are loaded/unloaded and banded or unbanded on the machines to prevent the coil's outer wraps from contacting other persons. Review Littell's Safety Awareness Report No. SAR-100 for additional information.

DESIGN & CONSTRUCTION

Littell has made extensive use of 1" x 1" x 1/8" steel angle, 16 gage sheet metal and flattened expanded metal as basic materials as they are light in weight, comparatively low in cost, available and provide a smooth exposed surface.

The steel angle provides maximum structural strength. The 16 gage sheet metal provides enclosure ability and is easily formed into irregular shapes or contours. The expanded metal allows good visibility, ventilation and observation of machine components. Maintenance and lubrication functions are aided as, oil gages, lubricant, and components requiring monitoring are visible through the expanded metal. Visibility is improved when the expanded metal is painted flat black.

All metal used in guard construction must be free from dangerous burrs and sharp edges. Expanded metal and sheet metal shall be securely attached to the frame of the guard by welding on center to center distance of 4" max. or less. Littell recommends welding as it is more suitable in withstanding the vibrations and other stresses associated with heavy industrial machinery.

All joints of the framework shall be made equivalent in strength to the frame material.

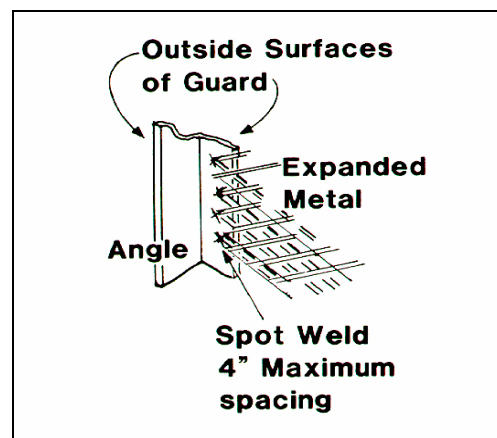

Standard Safety Caution Plates:

In order to alert and remind everyone involved with this machinery of the hazards resulting from unsafe practices and procedures, the following signs should be applied by the user. Littell has mass produced and inventoried these standardized safety caution signs and is using them on our newly manufactured machines. Littell strongly recommends that users request and apply these signs to their Littell Machines as soon as possible. These signs are not meant to frighten anyone; nor should they be interpreted to mean that the machine is unsafe. They should be permanently located and securely fastened nearest each machine's push button control station for immediate recognition.

Signs are OSHA Black and Yellow coated metal .062" THK. x 6.00" WIDE x 5.00" HIGH.

CAUTION

- **READ & COMPLY** with the Littell instruction manual before installing, using or servicing this machine.
- **NEVER** exceed the maximum machine capacities. Consult the Littell manual for capacity limitation and warnings.
- **NEVER** modify, alter or change the design, or intended use of this machine. If this machine does not meet your requirements, discontinue its use immediately and notify Littell.
- **BEFORE** servicing or repairing, always use proper tag and lockout safety procedures to exhaust, disconnect, and control all hazardous energy and motion, both entering or contained within this machine.

- **NEVER REMOVE OR DISFIGURE THIS PLATE**

PLATE NO. 145897
LITTELL

General Plate No. 145897

CAUTION

HAZARDOUS AREA-READ FOLLOWING CAREFULLY.

- **MAINTAIN SAFE CLEARANCE:** Machine starts automatically at any time by remote control.
- **NEVER** Rely on the strip loop position control to maintain a machine stop condition: Disconnect it's power supply.
- **BEFORE** and during operation make certain everyone is clear of the straightener, strip, coil and uncoiler.
- **NEVER** place your hands or fingers, with or without gloves on or near revolving rolls or moving strip for any reason.
- **NEVER** thread or enter a coil strip into revolving rolls.
- **NEVER** operate with any safeguard removed or missing. Discontinue using until all are replaced & functioning.
- **NEVER** leave machine operating unattended.

- **NEVER REMOVE OR DISFIGURE THIS PLATE No. 147606**

LITTELL

Straightener Plate No. 147606

CAUTION:

It is the user's responsibility to interpret and explain all safety precaution and signs to persons who do not read or understand English before they are allowed to use and care for Littell Machinery.

Inspect frequently to prevent signs from being hidden or covered and replace when defaced or significantly damaged.

The user should add additional signs to warn against hazards which result from other auxiliary equipment which he or others have combined with Littell Machinery.

CAUTION

HAZARDOUS AREA-READ FOLLOWING CAREFULLY.

- **MAINTAIN SAFE CLEARANCE:** Machine starts automatically at any time by remote drive control.
- **MAKE CERTAIN** the press or shear has been turned off, its flywheel stopped and the feed & cutter power supply disconnected & locked out before set up, servicing & repairing.
- **BEFORE** and during operation make certain everyone is clear of the cutter, press, feed, strip, straightener, coil and uncoiler.
- **NEVER** place your hands or fingers, with or without gloves, on or near revolving rolls or moving strip for any reason.
- **NEVER** thread or enter a coil strip into revolving rolls.
- **NEVER** operate with any safeguard removed or missing. Discontinue using until all are in place and functioning.
- **NEVER** leave machine operating unattended.

- **NEVER REMOVE OR DISFIGURE THIS PLATE No. 147605**

LITTELL

Feed & Cutter Plate No. 147605

CAUTION

HAZARDOUS AREA-READ FOLLOWING CAREFULLY

- **MAINTAIN SAFE CLEARANCE:** Machine starts automatically by remote control.
- **STAY CLEAR** of Revolving Spindle, Keepers, Coil & Moving Strip.
- **LOAD ONLY** Stable, Banded or Retained Coils.
- **MAKE CERTAIN** this machine safely supports and controls the coil before removing the coil loading device.
- **NEVER OVERLOAD:** Excessive force applied by cranes, forklifts, or other loading devices may cause the loss of safe coil support and control. Inspect daily for machine damage and repair before using.

- **NEVER REMOVE OR DISFIGURE THIS PLATE**

PLATE NO. 145896
LITTELL

Uncoiler Plate No. 145896

Safety Precautions:

WARNING:

READ AND UNDERSTAND ALL OF THE FOLLOWING. FAILURE TO COMPLY WITH ANY ONE PRECAUTION MAY CAUSE SERIOUS BODILY INJURY TO YOURSELF OR OTHERS. ONLY PERSONS WHO THOROUGHLY UNDERSTAND AND COMPLY WITH ALL OF THE FOLLOWING SAFETY PRECAUTIONS ARE QUALIFIED TO SAFELY USE AND CARE FOR LITTELL MACHINERY.

GENERAL

- Read and comply with the straightening machine instruction manual before installing, using or servicing.
- Never exceed the maximum machine capacities. Consult the instruction manual for capacity limitations and additional safety precautions.
- Never modify, alter or change the design or intended use of the machine. If it doesn't meet your requirements, discontinue its use immediately and notify Littell.
- Before servicing, repairing, maintaining, or cleaning, always use proper tag and lockout safety procedures to exhaust, disconnect, and control all hazardous energy and motion, both entering and contained within this machine.
- Before using, read, understand, and comply with all safety warnings.
- Know the location and access to the emergency stop controls.
- Before using, know what machinery safeguards exist and their proper location.
- Never operate the machinery with its safeguards removed or missing. Discontinue using until all are replaced and properly functioning.
- Maintain a sense of personal safety awareness. Observe all safety warnings and practices. Be on the lookout for hazardous conditions. Report hazards and obtain instruction for their control from your supervisor.
- Before operating machinery, always make certain all persons are in a safe location.
- Before loading, know the weight of the coil, and capacity of spindle and material handling equipment.
- Stay alert; don't become careless or overconfident. Avoid preoccupation, inattention, distraction, and talking when loading and using uncoilers/recoilers.
- Use personal protective equipment and clothing such as safety glasses, helmets, gloves, spats, shoes, and protective sleeves as required to suit the operation.
- Never wear clothing or jewelry that could cause part of the body to be caught or dragged into moving coil, strip or machinery.
- Protect yourself and others from injury by never bypassing, or eliminating any safety device, feature or procedure.
- Always make certain all loading area barriers, fences, gates, or other local safeguarding is in position before handling hazardous coils, releasing coil retaining bands, threading coil strip, uncoiling or recoiling operation.
- Only load coils on uncoilers and recoilers which are securely fastened to their foundations.
- Always stay safely clear of the dispensing spindle when handling materials around double spindle machines.
- Always maintain alignment of coil with the related pull-off equipment to prevent interface and jams between coil strip and coil retainers.
- Never manually adjust coil alignment while machine is operating.
- Only load or unload stable, banded or retained coils.
- Maintain an uncluttered and unobstructed coil handling area.
- Never position yourself under the coil load.
- Always transport and maneuver a coil slowly and cautiously.

Safety Precautions: (Cont'd)

- Never create a hazard by transporting a coil over other persons.
- Never block or obstruct your vision while moving coils.
- Always move coil cautiously to maintain a balanced load.
- Never swing or lose control of the coil's momentum.
- Keep loading hooks from becoming entangled or caught on the spindle or coil when removing them.
- Work at a safe pace. Coils moved rapidly are dangerous and can cause severe crushing damage.
- Always be alert when handling large diameter and narrow width coils balanced on "C-hook lifters" as they can be very dangerous to lift and transport.
- Use care and good judgment in material handling operations. Never transport, stack, store, or position coils unsafely.
- Position yourself safely when releasing the coils retaining bands. Coils can produce erratic, violent, rapid telescoping, unwinding of the coils outer wraps, along with dangerous spring action of the retaining bands when released.
- Before using, inspect the lifting device and discontinue using if significantly worn or damaged until repaired.
- Never balance a coil on the end of the spindle or use it as a temporary resting position while repositioning or reconnecting the lifter hook or other loading device.
- Always plan ahead and watch for the tail clearance in the coil eye while loading or unloading.
- Loosely wound coils can be unsafe when unbanded and about to fall apart.
- Never leave a coil load hanging unattended.
- Always finish your banding or unbanding procedures. Never create a hazard by leaving a potentially unstable coil with partial or incomplete banding.
- Never raise coils higher than necessary when transporting safely.
- Never use a defective sling or other lifting device. If in doubt about its condition, ask your foreman before using.
- Never position coils that result in blocking or obstructing access to aisles, exits, fire fighting or emergency equipment, electrical controls, control valves, or other important items.
- Cut off all loose banding that protrudes unsafely beyond the coils.
- Never leave tools where they may become a tripping hazard.
- Never rest coils upon any electrical, pneumatic, hydraulic lines, cables, hoses, or other power pipes/conduits.
- Follow only your instructed work procedures that you have been trained for. If a new or unfamiliar situation arises, ask your foreman for safe instructions before proceeding.
- Always store/position the lifting and loading device in a safe location between using intervals.
- Never place any part of the body in a crush or danger point between coil and other fixed or moving objects.
- Before and during the indexing of double spindles make certain all persons maintain a safe clearance from the machine, coil, adjacent structures, equipment and other materials.
- Before using, loading or unloading make certain the spindle turret housing is properly positioned and locked.
- Before loading or unloading always radially position and contract the spindle arms to safely clear the coil, coil eye tail, and the loading support device.

Safety Precautions:(Cont'd)

- Make certain the spindle expansion handcrank is folded in position to clear the coil during loading/unloading and before uncoiling or recoiling.
- Always apply the spindle brake before spindle expansion or contraction and uncoiling or recoiling.
- Never “SHOCKLOAD - OVERLOAD - OR DROPLOAD” other spindle, coil, or loading device.
- Never place any part of the body within the spindle or between coil during spindle expansion, contraction, loading or unloading.
- Never strike, bounce, impact or collide a coil or loading device against the spindle or rear coil retainers.
- Always support the coil with the loading device while expanding the spindle into the coil eye.
- Never overload the spindle, coil or coil support by exerting excessive lifting pressure against them.
- Never allow a loading device to move unsafely into a rotating spindle, coil, or moving strip.
- Use caution when removing “C-HOOK LIFTERS” from spindle area to prevent catching or hooking upon the spindle and resulting in overload damages to both hook and spindle.
- Make certain you apply and lock the spindle front coil retainers immediately after the coil is positioned against the rear retainers while coil support is maintained by the loading device.
- Never rush through any coil handling or loading/unloading procedures. Mistakes can easily occur and result in serious injury to yourself or other persons.
- Never use spindle expansion hand crank extensions other than originally designed and supplied to prevent machine and coil overloads.
- Always apply and lock front coil retainers against the coil before expanding spindle, removing the coil loading device and coil retaining bands.
- Before uncoiling or recoiling make certain the spindle is fully expanded against the coil eye.
- Watch out for explosive coils when releasing retaining bands. Review Littell Safety Awareness Report No. SAR100 for additional warnings.
- Never hand thread the coil strip into powered rotating rolls. Review Littell Safety Awareness Report No. SAR102 for additional warnings.
- Always maintain a safe clearance as the machine starts automatically by remote control.
- Stay clear of revolving spindle, coil retainers, coil and moving strip.
- Never attach, adjust or remove spindle coil retainers while the spindle is in motion.
- Never adjust spindle expansion hand crank while the spindle is in motion.
- Never touch the unsafe moving coil strip, with or without gloves, while automatically uncoiling or recoiling.
- Never position yourself under, above or in the direction and path of a coil strip.
- Never cross over or under operating equipment or the coil strip.
- Never rely or depend upon the uncoiler loop control arm or remote loop sensing device stop control to MAINTAIN a machine “STOP CONDITION”.
- Never position yourself or your hands on or near powered rolls for any reason.
- Never leave the uncoiler or recoiler unattended with the power turned on.
- Always reduce speed before coil is completely dispensed to prevent unsafe whip lash motion of the strip tail.

Safety Precautions:(Cont'd)

- Always reduce speed before coil is completely wound to prevent unsafe orbiting of the strip tail.
- Maintain a safe strip tension during uncoil or recoiling.
- Always adjust the spindle brake to prevent internal unwinding of the coil.
- Always adjust the spindle brake to prevent OVERCOASTING of the coil during slow down or stopping.
- Always make certain the Emergency Stop brake is properly functioning by frequent testing.
- Never attempt to stop or slow down a coil or spindle by grabbing at its moving parts or by using any part of your body as a brake.

SAFE LOADING SEQUENCE

1. Prevent spindle from automatically rotating.
2. Remove spindle arm front coil retainers.
3. Contract spindle arms to safely clear coil eye and coil tail.
4. Release spindle brake.
5. Before lifting the coil, radially position the loading device in relation to the coil tail so both will clear the spindle arms.
6. Safely position a retained and stable coil in front of the spindle - DO NOT LOAD ON SPINDLE - compare exact location of loading device and tail in coil eye with location of spindle arms.
7. Radially position spindle arms to clear coil loading device and coil tail.
8. Position coil eye concentric with center of spindle.
9. Cautiously spear coil eye by slowly moving the coil and position against rear retainers without shock impacting. Continue to support coil on loading device.
10. Apply and lock all front coil retainers against coil.
11. Lower center of coil eye just slightly below center of spindle. Continue to support coil on loading device.
12. Expand spindle and slowly lift coil weight of the loading device just prior to full spindle engagement within the coil eye. Continue to

expand until all arms are securely against coil.

WARNING:

IF COIL IS POSITIONED TOO HIGH - DO NOT OVERLOAD BY EXERTING SPINDLE EXPANSION PRESSURE AGAINST THE LOADING DEVICE - REVIEW SEQUENCE 11 & 12.

13. Establish clearance of loading device and remove safely.

SAFE UNLOADING SEQUENCE

1. Prevent spindle from automatically rotating.
 2. Safely position and secure the coil's strip end.
 3. Apply coil retaining bands to help contain and stabilize coil.
 4. Withdraw any auxiliary equipment from coil.
 - 4A. Release coil tail clamp if present.
 5. Release spindle brake.
 6. Radially position spindle arms and coil tail to clear coil unloading device.
 7. Apply spindle brake.
 8. Position unloading device to receive coil weight.
 9. Slowly contract spindle assembly to lower the coil weight on the unloading device.
 10. Contact spindle to safely clear coil eye and coil tail.
 11. Inspect coil and unloader for safe coil support and stability.
 12. Unlock and remove spindle arm front coil retainers.
 13. Cautiously remove coil from spindle and transport to a safe storage area.
- Never rely or depend upon the uncoiler control arm or remote loop sensing device stop control to MAINTAIN a machine stop condition.
 - Never remove, by-pass, or circumvent a safety interlock.
 - Only qualified electrical, pneumatic, or hydraulic personnel should work on respective circuitry.

Safety Precautions: (Cont'd)

- Before and during servicing, repairing, and maintaining or cleaning, always maintain a machine shutdown by tagging and locking out the electrical disconnect switch located on the straightener supply source to prevent other persons from accidentally restarting the machine.
- Always Tag, Lockout, Vent and Exhaust hydraulic and pneumatic pressure that, as stored or trapped energy, could cause dangerous machinery motion.
- Always make certain all machinery components will maintain a safe position during all maintenance and repairs by using adequate physical blocking, restraint, and control procedures. Never depend upon the machine's hydraulic or pneumatic power to hold or maintain any component in a constant position.



Train, Instruct and Supervise for Safety...

A SAFETY FIRST WARNING

It is impossible to foresee all possible uses, and applications of this machine. Therefore it is also impossible, to warn you in advance of every possible hazard, or to tell you that this machine will always be absolutely "hazard free". Your best protection against injuries to yourself or others is to always be cautious and remind yourself to think "SAFETY FIRST" before attempting any questionable, unfamiliar, infrequent, physical involvement with this machine that you have NOT been specifically trained for. When these situations arise, act cautiously; think "SAFETY FIRST", and protect yourself and others by requesting detailed safety instructions and related training from your management before attempting any such involvement for the care and use of this machine.



DIRECTORY	
SAFETY LITERATURE / STANDARDS / REGULATIONS	
<p>The following is a list of some of the Federal Regulations and other safety literature which users should obtain and review before applying safeguards to Littell Products. Each publication has been cross referenced to some (but not necessarily all) of the areas in which they are involved. Many other publications exist (such as American National Standards) and can be easily identified in the "Sources of Standards" listed in the OSHA Federal Regulations below.</p>	
APPLICABLE SAFETY LITERATURE / STANDARDS / REGULATIONS	INVOLVEMENT AREA
<p>"Accident Prevention Manual for Industrial Operations." By National Safety Council - Chicago, IL 60611</p>	<ul style="list-style-type: none"> ● Complete Sourcebook for industrial safety.
<p>"Guards - Illustrated - Ideas for Mechanical Safety." By National Safety Council - Chicago, IL 60611</p>	<ul style="list-style-type: none"> ● Machine guarding Methods and devices.
<p>Littell Safety Awareness Report No. SAR-100 - Unbanding Coils. Littell Safety Awareness Report No. SAR-101 - Safeguarding and Safety Precautions for Feeding Machines. Littell Safety Awareness Report No. SAR-102 - Safeguarding and Safety Precautions for Coil Strip Straightening Machines. Littell Safety Awareness Report No. SAR-108 - Roll Cleaning Safety Precautions.</p>	<ul style="list-style-type: none"> ● Specific safety instructions and safety precautions on the safe-guarding, care and use of Littell products.
<p>OSHA - Part 1910 - Subpart D - Walking and Working Surfaces. SECTIONS: 1910.21 Definitions. 1910.22 General Requirements. 1910.23 Guarding Floor and Wall Openings and Holes. 1910.24 Fixed Industrial Stairs. 1910.25 Portable Wood Ladders. 1910.26 Portable Metal Ladders. 1910.27 Fixed Ladders. 1910.28 Safety Requirements for Scaffolding. 1910.31 Sources of Standards.</p>	<ul style="list-style-type: none"> ● Access to Press Crank Shaft of Feeders - Drive Adjustments. ● Protection from Floor Pits for Strip Loop Storage. ● Access to "Hard To Reach" areas of large machinery for servicing or repairing.
<p>OSHA - Part 1910 - Subpart J - General Environmental Controls. SECTIONS: 1910.144 Safety Color Code for marking Physical Hazards. 1910.145 Specifications for Accident Prevention Signs and Tags. 1910.147 Sources of Standards.</p>	<ul style="list-style-type: none"> ● Regulations for identifying and communicating hazards
<p>OSHA - Part 1910 - Subpart N - Material Handling and Storage. SECTIONS: 1910.176 Handling Material - General. 1910.178 Powered Industrial Trucks. 1910.179 Overhead and Gantry Cranes. 1910.184 Slings. 1910.189 Sources of Standards.</p>	<ul style="list-style-type: none"> ● Safe care and use during service or repairs of machines. ● Safe Coil Handling & Loading. ● Safe Scrap Handling & Unloading.
<p>OSHA - Part 1910 - Subpart O - Machinery and Machine Guarding. SECTIONS: 1910.211 Definitions. 1910.212 General Requirements for All Machines. 1910.217 Mechanical Power Presses. 1910.219 Mechanical Power Transmission Apparatus. 1910.221 Sources of Standards.</p>	<ul style="list-style-type: none"> ● Safeguarding of all machine hazards. ● Mechanical Power Presses used with Littell Roll Feeds Safely.
<p>OSHA - Part 1910 - Subpart S - Electrical. SECTIONS: 1910.308 Application. 1910.309 National Electrical Code.</p>	<ul style="list-style-type: none"> ● Safe addition of electrical interlocks. ● Safe care and use of machinery with electrical power.
<p>American National Standard Institutes. Safety Requirements for the Construction, Care, and Use of Shears No. ANSI-B11.4. American National Standard Institutes. Safety Requirements for the Construction, Care, and Use of Mechanical Power Presses No. ANSI-B11.1</p>	<ul style="list-style-type: none"> ● Safe care and use when combined with Littell Products.

Additional copies of this Safety Awareness Report are available and supplied free to all our product users when requested. We recommend that users place this report in existing Littell machinery instruction or service manuals which should always be readily available to everyone involved with this machinery allowing them to maintain familiarity with all safeguards, their purpose, location, and warnings.

If you should need additional information or copies contact the Littell Service Department.

Although this report is not a "SAFETY CODE OR STANDARD", the addition of safeguarding and adherence to the safety precautions contained in this report will assist users in complying with the existing Federal Regulations.

This Safety Awareness Report was produced and freely distributed because Littell cares about the safety of its product users. Please help reduce hazards and prevent accidents by complying with its instructions.

special note:

LITTELL assumes no responsibility in connection herewith, nor can it be assumed that all acceptable safety measures are contained in this publication, or that other additional measures may not be required under particular or exceptional circumstances or conditions.

LITTELL INTERNATIONAL, INC.

145 SWIFT ROAD
ADDISON, ILLINOIS 60101-1407, U.S.A.
AREA CODE: (630) 916-6662
LITTELL TELEFAX: (630) 916-6663
SERV. DEPT TELEFAX: (630) 916-6664