

### SUBJECT:

## SAFEGUARDING PROGRAM FOR EXISTING LITTELL SCROLL SHEETING LINES.

### INTRODUCTION:

The intent of this report is to state safeguarding objectives concerning the existing Littell Scroll Sheeting Line.

Your line was originally manufactured with safeguarding beyond the "State of the Art," yet today a high probability exists that additional safeguarding methods have been developed over recent years which should be applied to all older equipment.

By reviewing this report, containing some examples of our latest methods, and by comparing these examples against your existing Littell Scroll Line, you should become aware of potential hazards and their proposed methods of safeguarding.

Safeguarding as shown may not be applicable to your particular line because equipment arrangement and design are not identical. Therefore, Littell will offer a safeguarding program and apply it to meet your specific line.

Littell urges you to use this report to help you evaluate your present safeguarding requirements. In the interest of safety, please contact the Sales Office to develop communications and request our SAFEGUARDING PROGRAM.

### CONTENT

	Page
Introduction.	1
Liability Note.	2
Overall view of typical Littell Scroll Sheeting Line.	2-3
Safeguarding from Downender to Straightening Machine.	4-5
Safeguarding from Press side catenary to No. 4 stacking pocket.	6-7
Recommended Roll Cleaning Method for Straightening Machine.	8

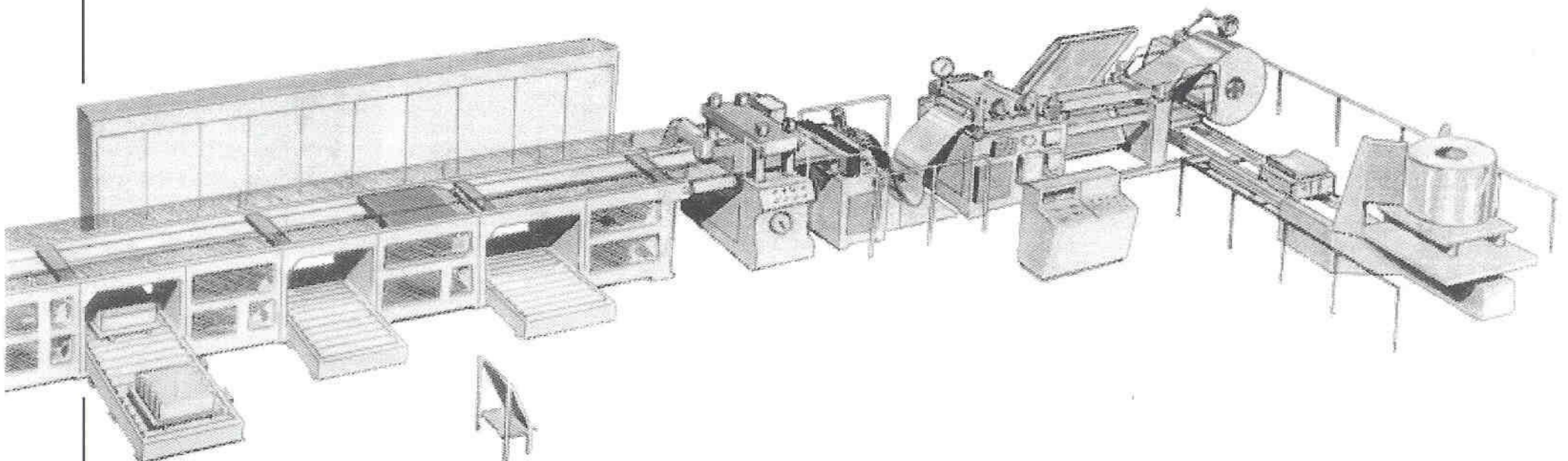



## LIABILITY

This Safety Awareness Report contains some examples of safeguarding presently incorporated on Littell's Scroll Sheeting Line. Due to product design variables, optional equipment, and accessories, safeguarding will vary and must be tailored to each individual machine and its environment. For this reason, Littell cannot illustrate in a general report of this type, all of the conceivable variations in safeguards which may be desirable for a particular Littell Scroll Sheeting Line now in use. However, Littell wishes to consult with any customers or users concerning the design of safeguards for their particular machines.

LITTELL ASSUMES NO RESPONSIBILITY in connection with the compliance of the examples or information herein with applicable OSHA regulations or other safety requirements. It should not be assumed that all acceptable safety measures are contained in this publication, or that other or additional measures may not be required under particular or exceptional circumstances or conditions.

LITTELL

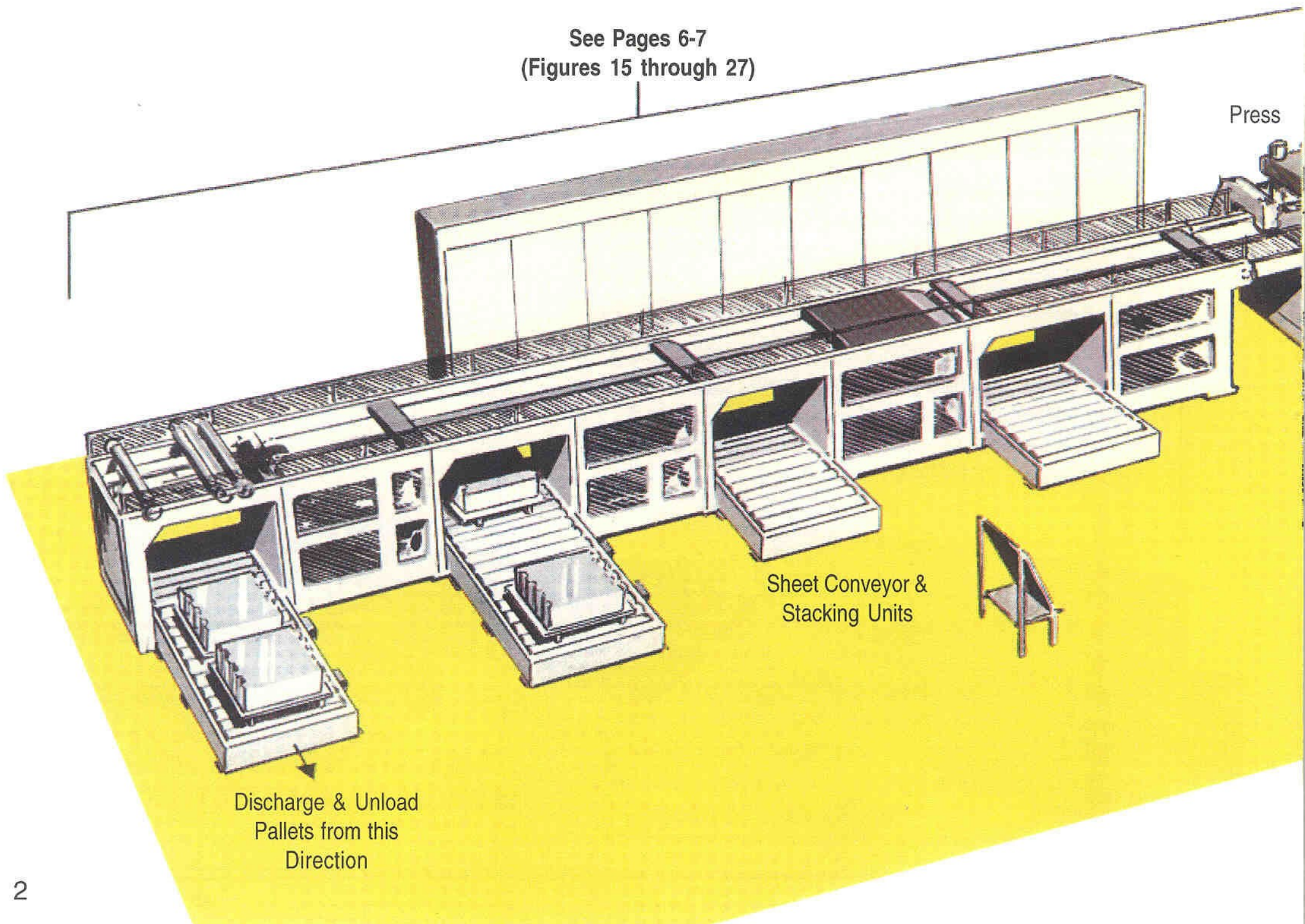



See Pages 4-5  
(Figures 1 through 14)

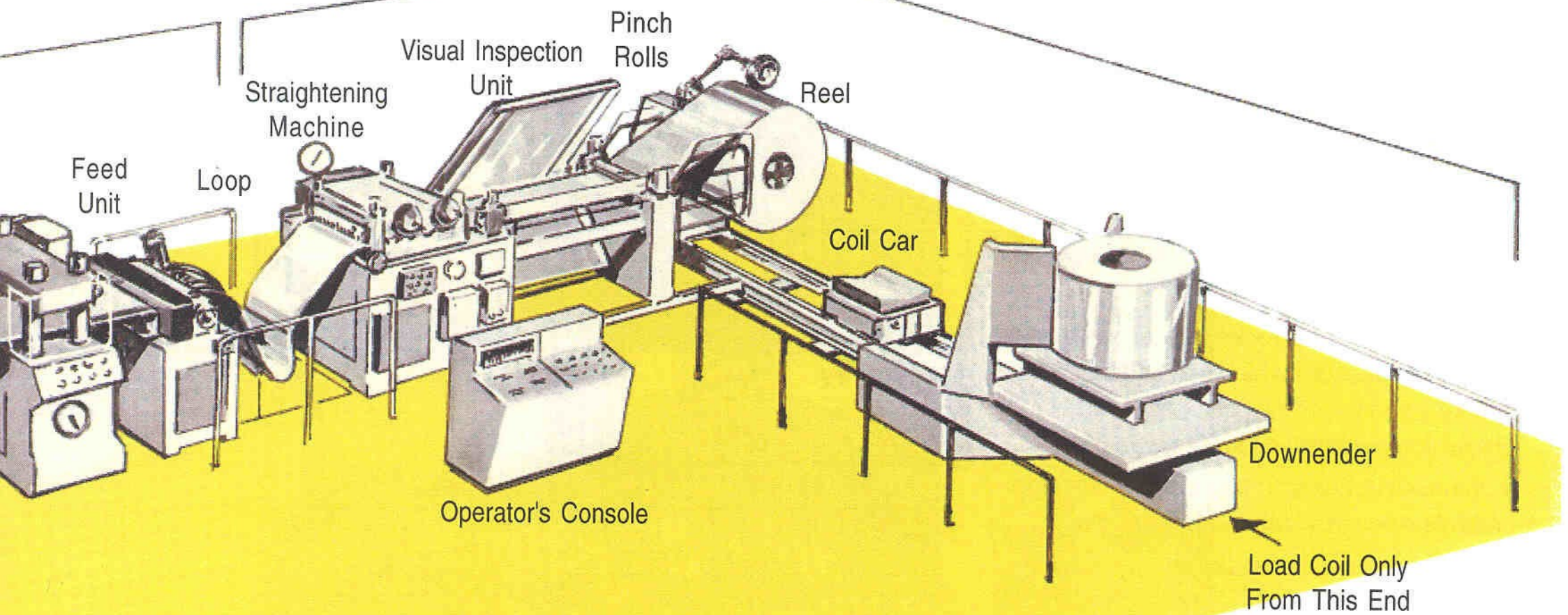

**NOTE**

Area safeguarding will vary and must be tailored to each individual installation by the user.

Guards, barriers and floor markings must conform to plant and local safety codes.



**Fig. 1** Awareness signal added to warn of Downender Movement. Horn Automatically sounds when Downender control push buttons are activated.

**Fig. 2** Magnetic switch on car track detects an improper position of car. Switch is interlocked to prevent Downender tilt control operation until car is properly positioned.

**Fig. 3** Sheet metal enclosure on both sides of car prevents access to wheel nip points.

**Fig. 4** Expanded metal enclosure on rear of reel housing restricts entry to rotating cylinder and brake.

**Fig. 5** Strip support table between reel and pinch rolls assists in strip threading operations.

**Fig. 6** Steel reinforced transparent plastic hinged safety gate on front and rear side restricts access to sharp strip edge between reel and pinch roll stand as well as pinch roll nip points.

**Fig. 7** Following system allows safe threading operations:

1. Opening front or rear safety gate between reel and pinch roll stand activates a covered limit switch.
2. Switches are interlocked to deactivate all hazardous functions which may endanger coil handling and threading personnel. All rotary propulsion pinch roll controls are inoperative.
3. Same switches activates emergency stop controls when in a "run mode".
4. Four buttons are located inside gate on pinch roll stand; "reel jog forward", "reel jog reverse", "pinch roll open" and "pinch roll closed".

**Fig. 8** Transparent plastic barrier mounted on pinch roll frame to restrict access to roll bearing box squeeze points, roll nip points, sharp strip edge, and moving strip.

**Fig. 9** Transparent plastic barrier mounted across length of visual inspection unit restricts access to sharp strip edge, and moving strip.

**Fig. 10** Transparent plastic barrier mounted

on front, between thickness gage and straightener head, which restricts access to sharp strip edge and moving strip.

**Fig. 11** Metal enclosures covering both upper and lower entry pinch rolls on straightener head prevent access to roller nip points.

**Fig. 12** Metal enclosures covering both upper and lower exit pinch rolls on straightener head prevent access to roller nip points.

**Fig. 13** Metal enclosure prevents over access to straightener and pinch rolls. plates cover upper pinch roll bearing squeeze points.

**Fig. 14** Limit switch releases pinch pressure when using the recommended straightener roll cleaning method shown on page eight.

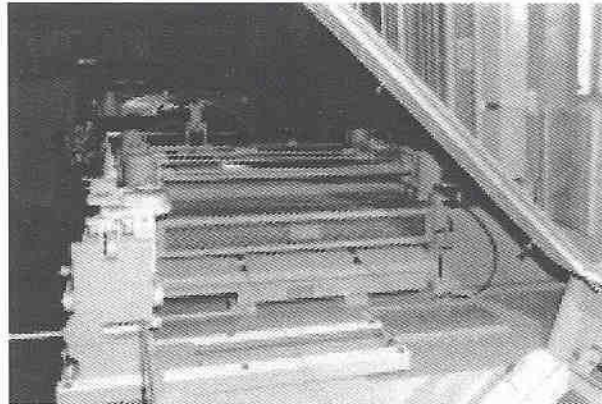

**Fig. 11**

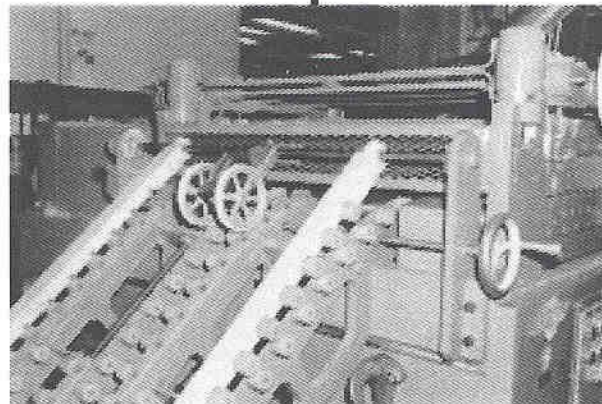

**Fig. 12**

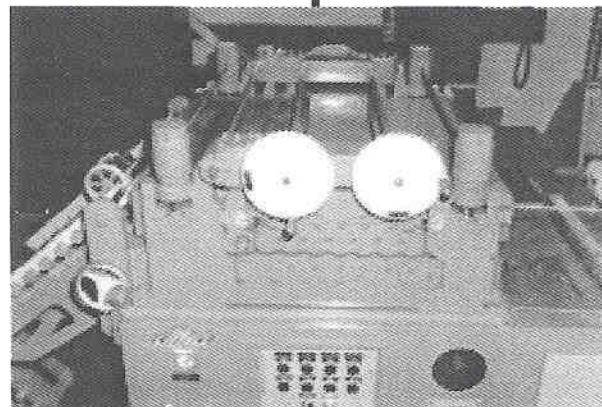

**Fig. 13**

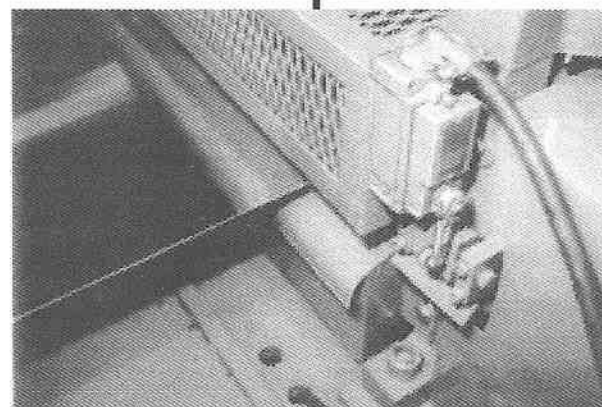

**Fig. 14**

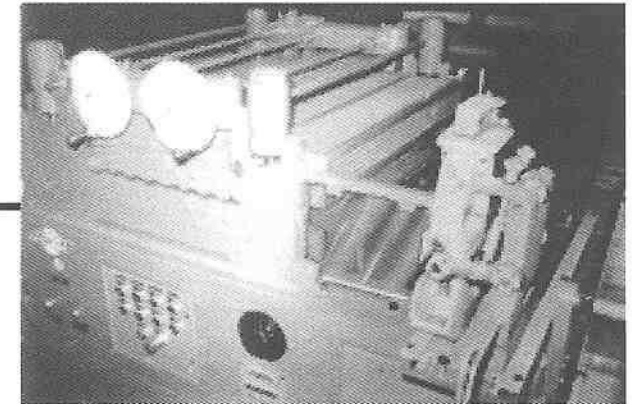

**Fig. 10**



Overhead  
Metal  
Storage box  
Roll air  
ended  
down on

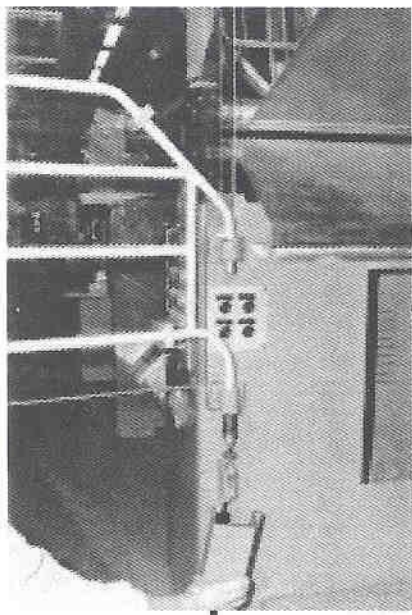

Fig. 7

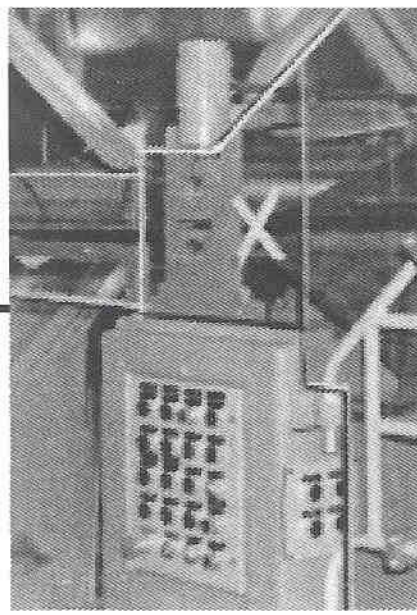

Fig. 8

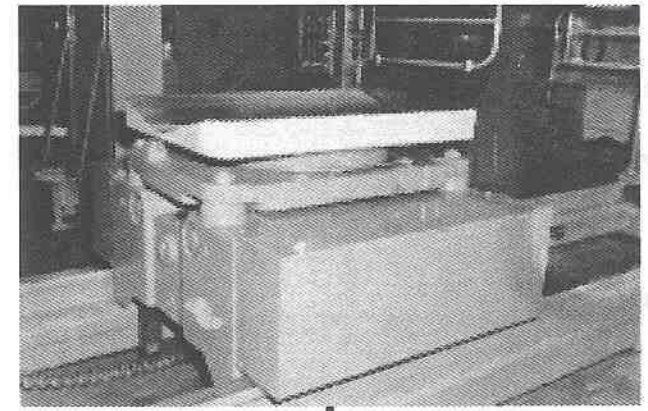

Fig. 3

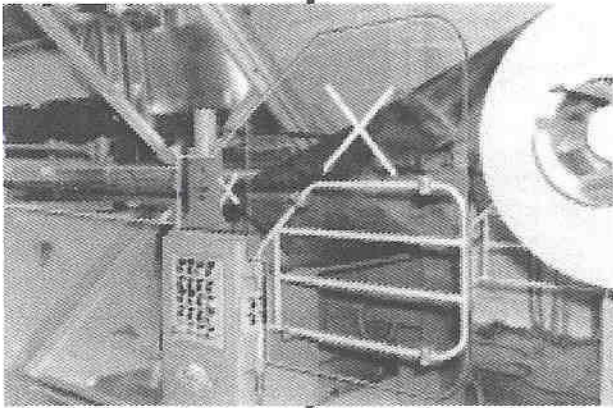

Fig. 6

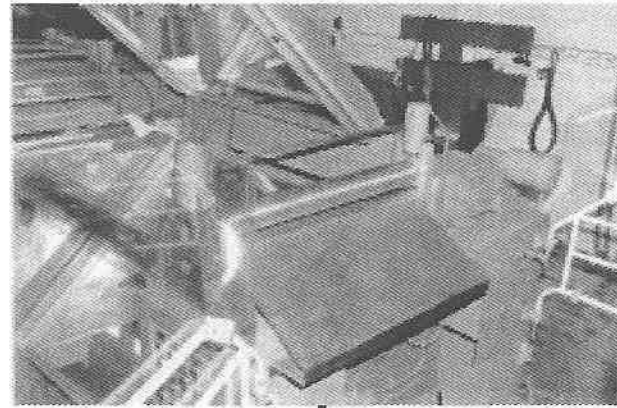

Fig. 5

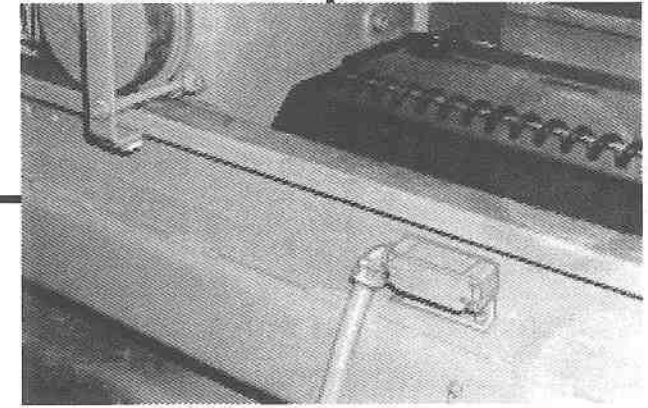

Fig. 2

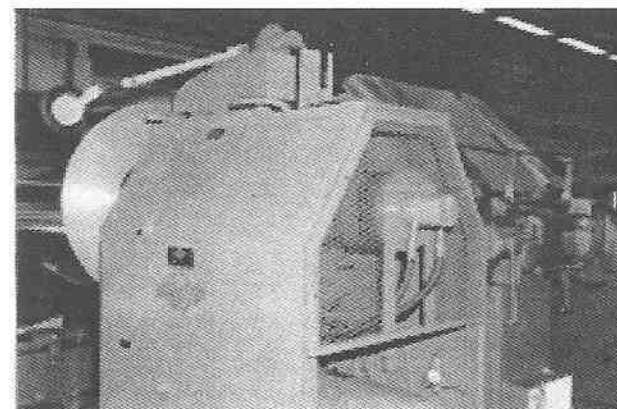

Fig. 4

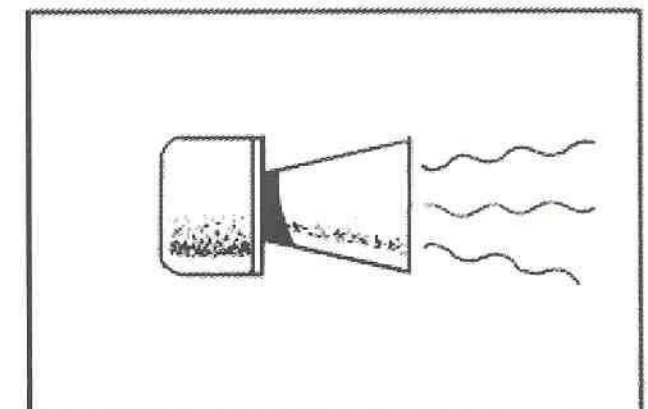

Fig. 1

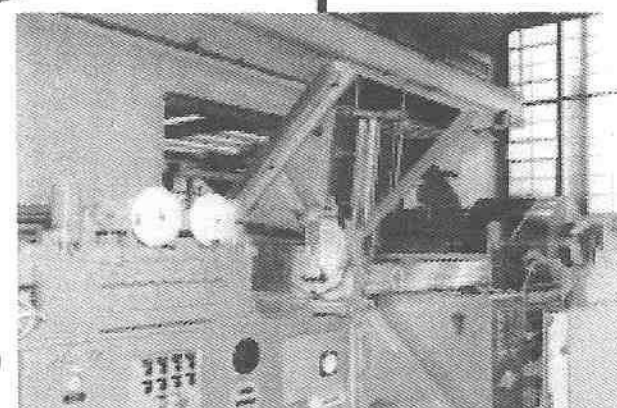
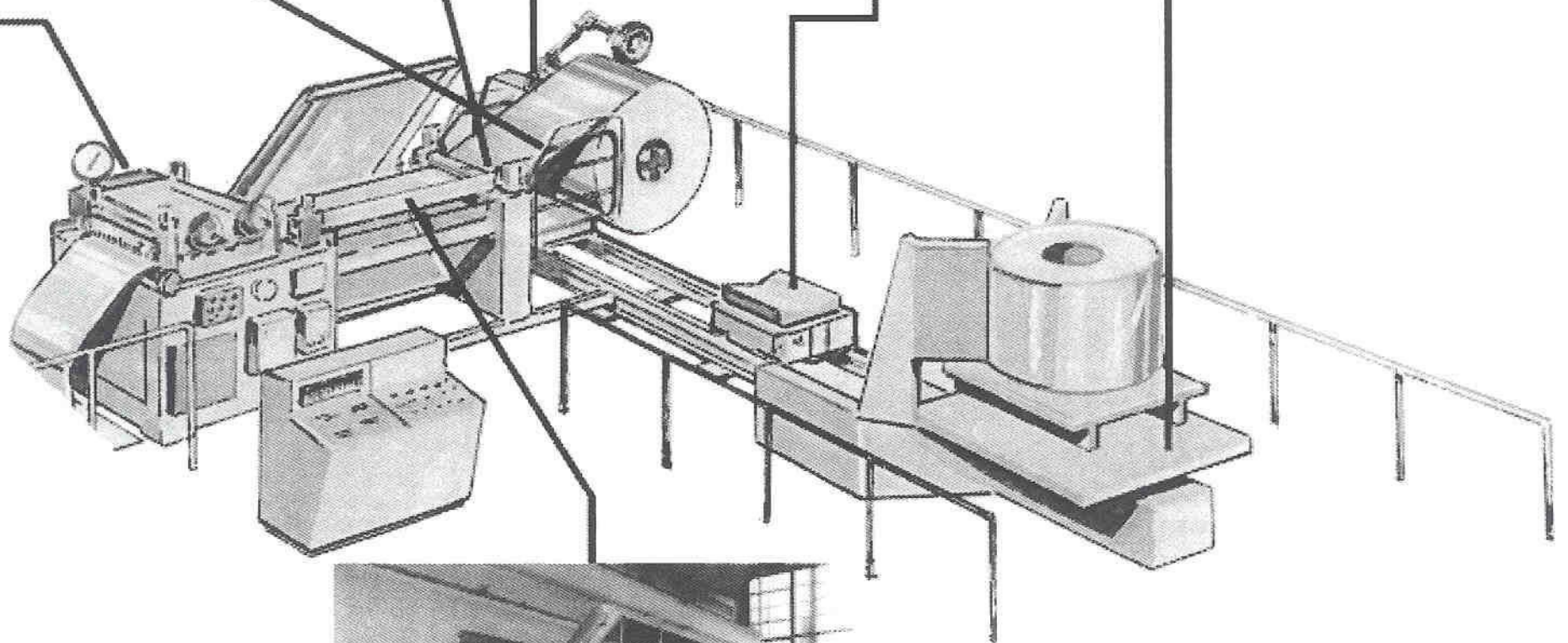

Fig. 9



# LITTELL

## SAR 107

**Fig. 15** Extended locking device and handle, for adjusting entry preguides, positions hands away from sharp strip edge, and moving strip.

**Fig. 16** Safety tread plates improves footing while making rear stock guide adjustments.

**Fig. 17** Sheet metal enclosure with electrically interlocked doors prevents unsafe access to pulse generator gear train.

**Fig. 18** Removable transparent plastic guard mounted on front of press prevents unsafe access to die area. When removed, electrical interlock produces emergency stop.

**Fig. 19** Removable transparent plastic guard mounted on rear of press prevents unsafe access to die area. When removed, electrical interlock produces emergency stop function.

**Fig. 20** Removable transparent plastic guard mounted on upper feed roll bonnet prevents unsafe access to upper feed roll. When opened, electrical interlock produces emergency stop function.

**Fig. 21** Press clutch double solenoid, double valve, will detect an asynchronous motion of valve elements and renders the valve inoperable and exhausts press clutch.

**Fig. 22** Two hand control for "Inch Mode" only.

**Fig. 23** Sheet metal barriers on underside of stacker entry conveyor restricts access to moving belts.

**Fig. 24** Expanded metal side barriers along entire length of conveyor and drive system restricts access to power transmission components, moving belts, and sharp edged sheets.

**Fig. 25** Self-locking latch operates at maximum raised position of entry conveyor.

**Fig. 26** Transparent plastic barrier located near "Ski-Jump" adjustment restricts contact with sharp edged moving sheets.

**Fig. 27** Barrier over No. 4 stacking station prevents sheets from leaving stacker area.

**NOTE:** Make certain safeguards originally supplied or specified are in proper use.



**Fig. 24**

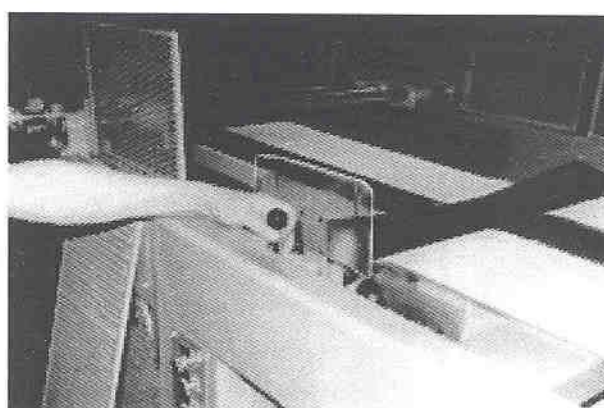

**Fig. 26**

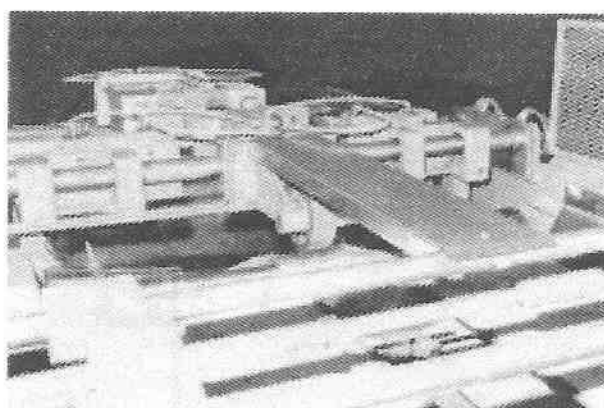

**Fig. 27**

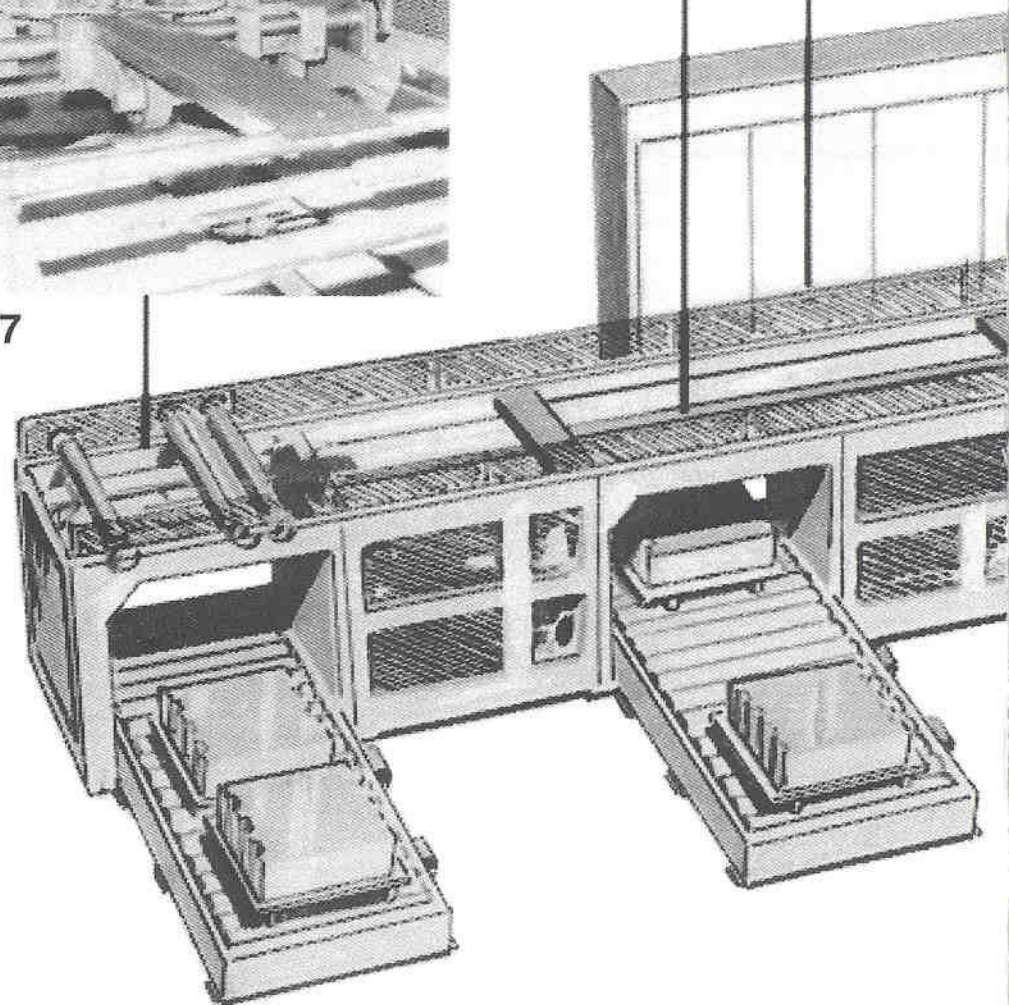



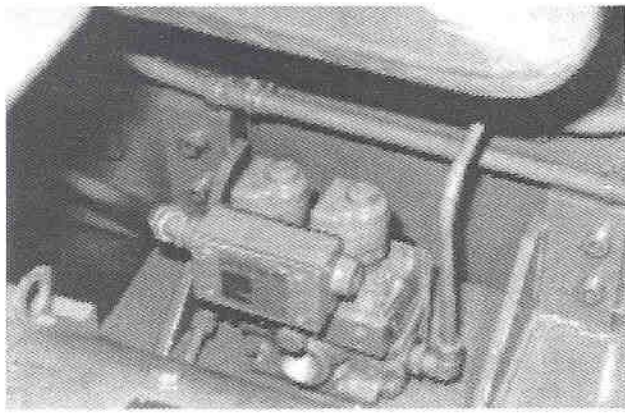

Fig. 21

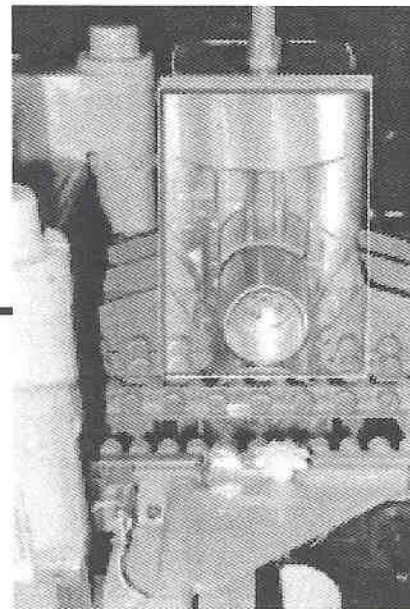

Fig. 20

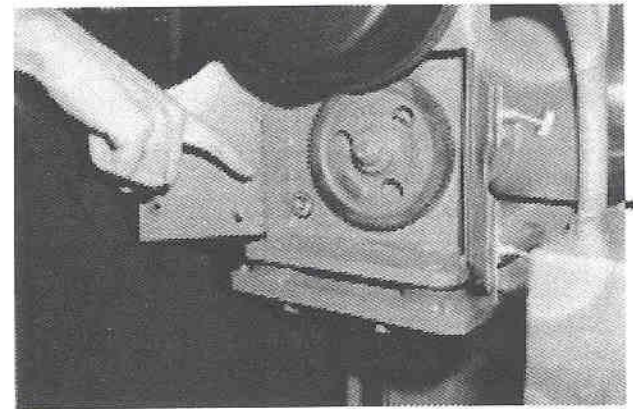

Fig. 17

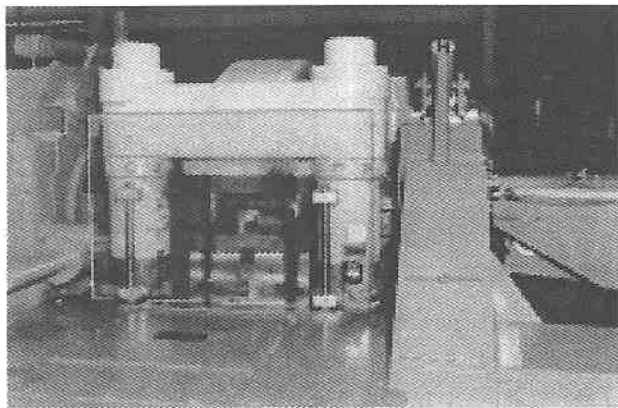

Fig. 19

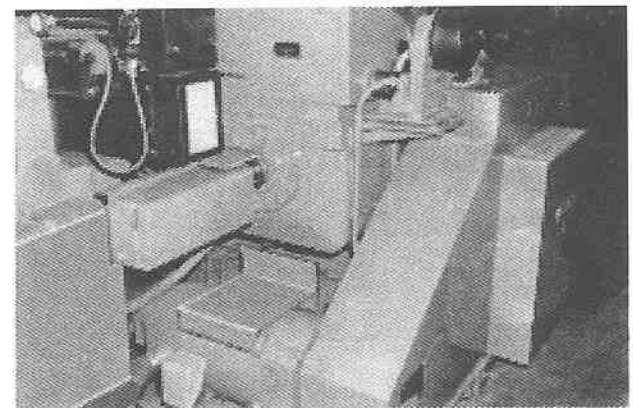

Fig. 16

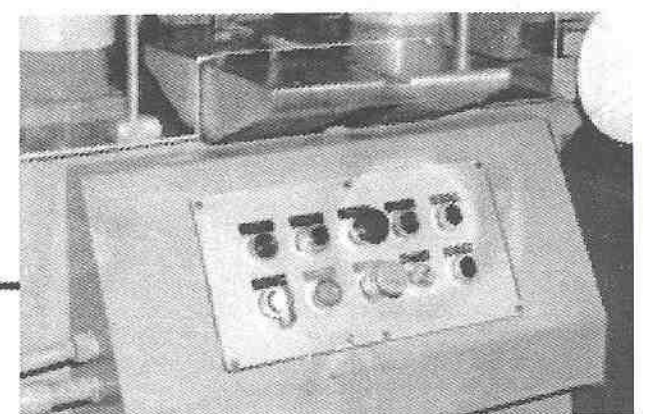
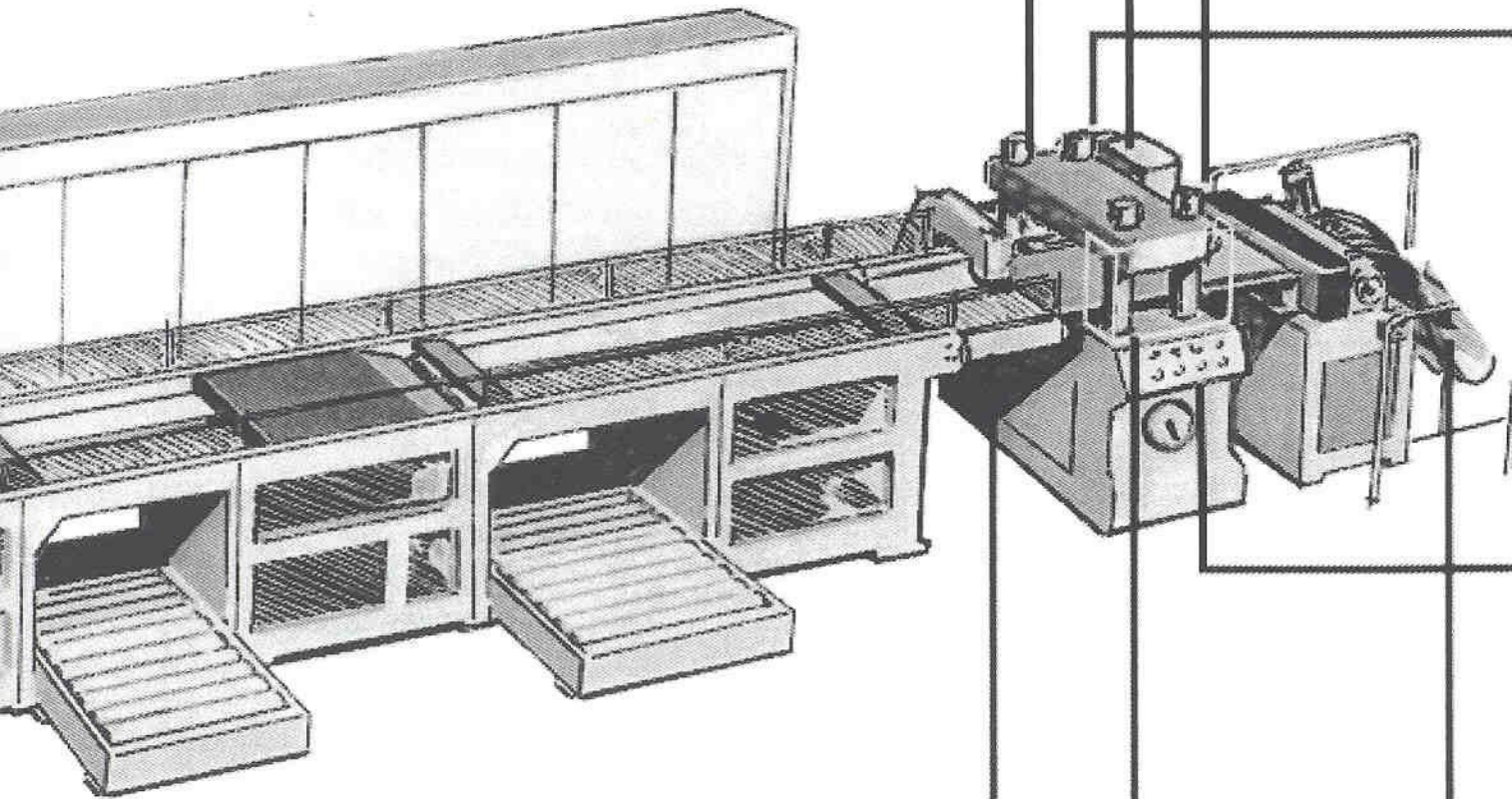

Fig. 22

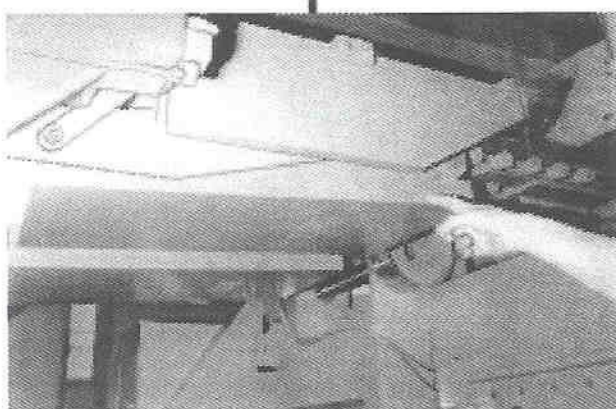

Fig. 23

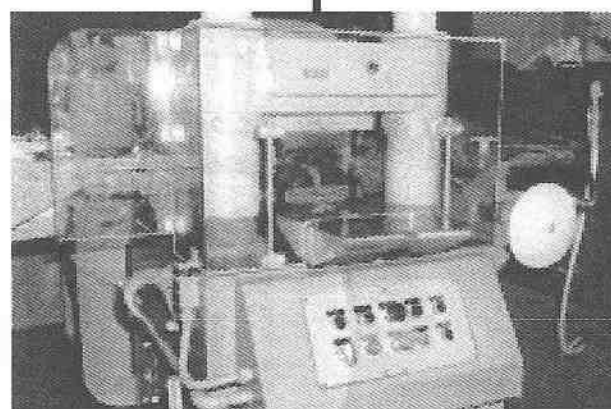

Fig. 18

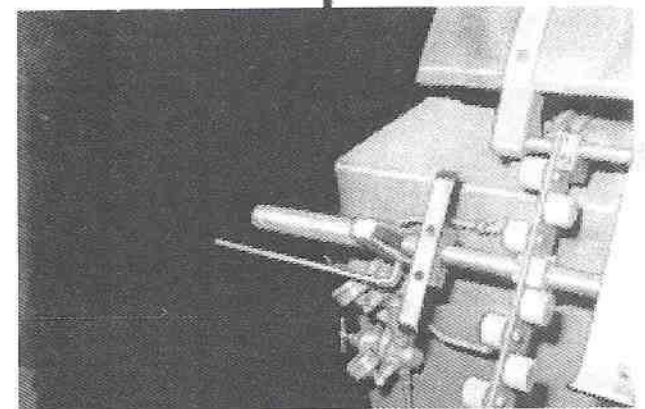

Fig. 15



Fig. 25



## Recommended Roll Cleaning Method for Straightening Machine.

Permanently mounted metal enclosures covering all pinch and straightening rolls (Shown in Figures 11, 12 and 13) prevent hazardous exposure to nip points.

This safeguarding limits access for manual hand roll cleaning and, therefore, the following cleaning method is recommended.

### Method

1. Fabric cleaning device (See Figure 28) is used for:
  - A. Transmit cleaning fluid to roll surfaces.
  - B. Provide scrubbing effect on rolls.
  - C. Collect roll contaminates.
2. Fabric must be saturated with nonflammable and nontoxic cleaning fluid prior to use.
3. Scrubbing action is developed by inching the main drive to propel rolls against fabric for several minutes.
4. The fabric is full roll width and has a rigid, tapered lead edge for threading through straightener head.

5. Cleaning device contains a removable restraining bar used for:
  - A. Actuation of Entry and Exit Pinch Roll pressure release controls to prevent fabric and drive overload.
  - B. Prevent fabric from being passed through straightener during cleaning operation.
  - C. Storage handles for hanging up fabric.
6. Durable, heavily stitched fabric which can be cleaned and reused.
7. Frequency of use depends on contaminate type, amount and product quality control.

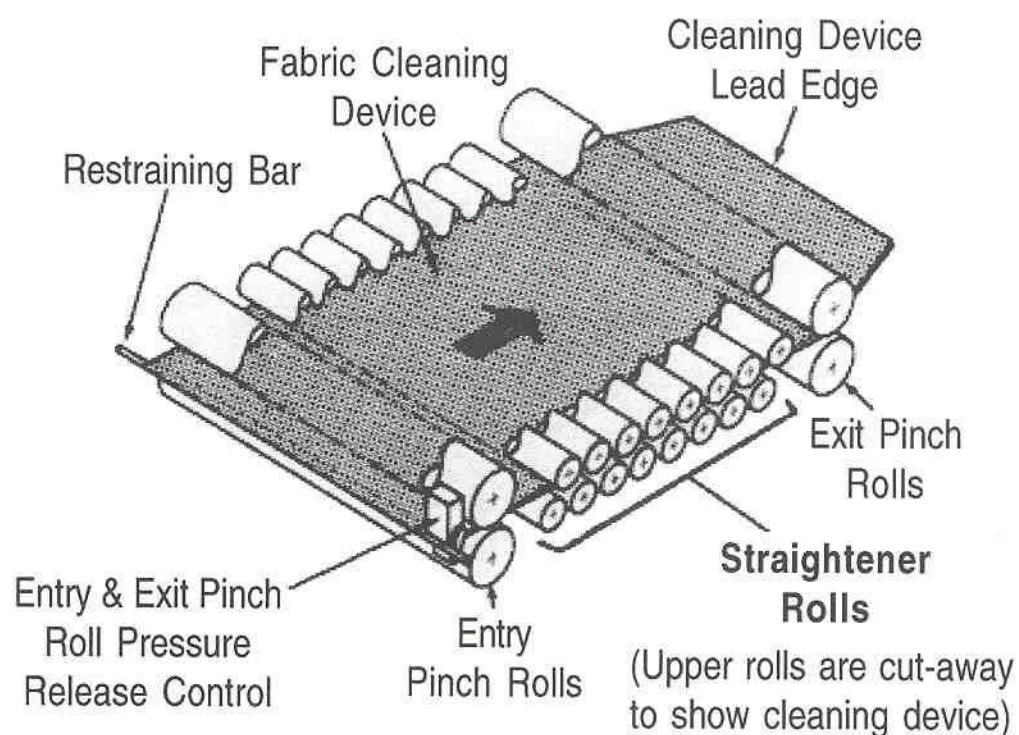

Fig. 28

**LITTELL INTERNATIONAL, INC.**  
145 SWIFT ROAD  
ADDISON, ILLINOIS 60101-1407, U.S.A.  
AREA CODE: (630) 916-6662  
LITTELL TELEFAX: (630) 916-6663  
SERV. DEP'T TELEFAX: (630) 916-6664

## special note:

LITTELL assumes no responsibility in connection herewith, nor can it be assumed that all acceptable safety measures are contained in this publication, or that other additional measures may not be required under particular or exceptional circumstances or conditions.